

**DIRECTORATE OF DISTANCE & CONTINUING EDUCATION  
MANONMANIAM SUNDARANAR UNIVERSITY  
TIRUNELVELI- 627 012**

**OPEN AND DISTANCE LEARNING (ODL) PROGRAMMES  
(FOR THOSE WHO JOINED THE PROGRAMMES FROM THE ACADEMIC YEAR 2023-2024)**



**B. Sc. Chemistry  
Course material**

**Core I - General Chemistry CCI  
Course Code JMCH11**

Prepared by  
**Dr. K. Nagashri**  
Assistant Professor  
Department of Chemistry  
Manonmaniam Sundaranar University  
Tirunelveli - 12

## Semester - I

Course: CORE - I

Course Code JMCH11

### General Chemistry - I

#### UNIT I : Atomic structure and Periodic trends

History of atom (J.J.Thomson, Rutherford); Moseley's Experiment and Atomic number, Atomic Spectra; Black-Body Radiation and Planck's quantum theory - Bohr's model of atom; The Franck-Hertz Experiment; Interpretation of H- spectrum; Photoelectric effect, Compton effect; Dual nature of Matter- De- Broglie wavelength-Davisson and Germer experiment Heisenberg's Uncertainty Principle; Electronic Configuration of Atoms and ions- Hund's rule, Pauli's exclusion principle and Aufbau principle; Numerical problems involving the core concepts.

#### UNIT-II: Introduction to Quantum mechanics

Classical mechanics, Wave mechanical model of atom, distinction between a Bohr orbit and orbital; Postulates of quantum mechanics; probability interpretation of wavefunctions, Formulation of Schrodinger wave equation - Probability and electron density-visualizing the orbitals -Probability density and significance of  $\Psi$  and  $\Psi^2$ .

#### Modern Periodic Table

**Cause of periodicity**; Features of the periodic table; classification of elements - Periodic trends for atomic size- Atomic radii, Ionic, crystal and Covalent radii; ionization energy, electron affinity, electronegativity- electronegativity scales, applications of electronegativity.

Problems involving the core concepts

#### UNIT-III: Structure and bonding - I

##### Ionic Bond

Lewis dot structure of ionic compounds; properties of ionic compounds; Energy involved in ionic compounds; Born Haber cycle – lattice energies, Madelung constant; relative effect of lattice energy and solvation energy; Ion polarisation – polarising power and polarizability; Fajans' rules - effects of polarisation on properties of compounds; problems involving the core concepts.

#### UNIT-IV: Structure and bonding - II

VB theory – application to hydrogen molecule; concept of resonance - resonance structures of some inorganic species –  $\text{CO}_2$ ,  $\text{NO}_2$ ,  $\text{CO}_3^{2-}$ ,  $\text{NO}_3^-$ ; limitations of VBT; MO theory - bonding, antibonding and nonbonding orbitals, bond order; MO diagrams of  $\text{H}_2$ ,  $\text{C}_2$ ,  $\text{O}_2$ ,  $\text{O}_2^+$ ,  $\text{O}_2^-$ ,  $\text{O}^{2-}$ ,  $\text{N}_2$ ,  $\text{NO}$ ,  $\text{HF}$ ,  $\text{CO}$ ; magnetic characteristics, comparison of VB and MO theories.

Coordinate bond: Definition, Formation of  $\text{BF}_3$ ,  $\text{NH}_3$ ,  $\text{NH}_4^+$ ,  $\text{H}_3\text{O}^+$  properties

Metallic bond-electron sea model, VB model; Band theory-mechanism of conduction in solids; conductors, insulator, semiconductor – types, applications of semiconductors

Weak Chemical Forces - Vander Waals forces, ion-dipole forces, dipole-dipole interactions, induced dipole interactions, Instantaneous dipole-induced dipole interactions. Repulsive forces; Hydrogen bonding – Types, special properties of water, ice, stability of DNA; Effects of chemical force, melting and boilingpoints.

### **UNIT-V: Basic concepts in Organic Chemistry and Electronic effects.**

Types of bond cleavage – heterolytic and homolytic; arrow pushing in organic reactions; reagents and substrates; types of reagents - electrophiles, nucleophiles, free radicals; reaction intermediates – carbanions, carbocations, carbenes, arynes and nitrynes.

Inductive effect - reactivity of alkyl halides, acidity of halo acids, basicity of amines; inductomeric and electromeric effects.

Resonance – resonance energy, conditions for resonance - acidity of phenols, basicity of aromatic amines, stability of carbonium ions, carbanions and free radicals, reactivity of vinyl chloride, dipole moment of vinyl chloride and nitrobenzene, bond lengths; steric inhibition to resonance.

Hyperconjugation - stability of alkenes, bond length, orienting effect of methyl group, dipole moment of aldehydes and nitromethane

Types of organic reactions- addition, substitution, elimination and rearrangements

#### **Recommended Text**

1. Madan, R. D. and Sathya Prakash, *Modern Inorganic Chemistry*, 2<sup>nd</sup>ed.; S. Chand and Company: New Delhi, 2003.
2. Rao, C.N. R. *University General Chemistry*, Macmillan Publication: New Delhi, 2000.
3. Puri, B. R. and Sharma, L. R. *Principles of Physical Chemistry*, 38<sup>th</sup>ed.; Vishal Publishing Company: Jalandhar, 2002.
4. Bruce, P. Y. and Prasad K. J. R. *Essential Organic Chemistry*, Pearson Education: New Delhi, 2008.
5. Dash UN, Dharmarha OP, Soni P.L. *Textbook of Physical Chemistry*, Sultan Chand & Sons: New Delhi, 2016

#### **Reference Books**

1. Maron, S. H. and Prutton C. P. *Principles of Physical Chemistry*, 4<sup>th</sup>ed.; The Macmillan Company: New York, 1972.
2. Lee, J. D. *Concise Inorganic Chemistry*, 4th ed.; ELBS William Heinemann: London, 1991.
3. Gurudeep Raj, *Advanced Inorganic Chemistry*, 26<sup>th</sup>ed.; Goel Publishing House: Meerut, 2001.
4. Atkins, P.W. & Paula, J. *Physical Chemistry*, 10th ed.; Oxford University Press: New York, 2014.
5. Huheey, J. E. *Inorganic Chemistry: Principles of Structure and Reactivity*, 4<sup>th</sup> ed.; Addison, Wesley Publishing Company: India, 1993.

## UNIT I- ATOMIC STRUCTURE AND PERIODIC TRENDS

### SUB-ATOMIC PARTICLES

#### Discovery of Electron

Electron was discovered by J J Thomson by *Cathode ray discharge tube experiment*. A cathode ray tube is made of glass containing two thin pieces of metal (called electrodes) sealed in it. The electrical discharge through the gases could be observed only at very low pressures and at very high voltages.

When a very high voltage (about 10,000 volts) is applied between the two electrodes, no electric discharge occurs at normal pressure. When the pressure of the gas inside the tube is less than 1 mm of mercury, a dark space appears near the cathode. When the pressure is reduced to 0.01 mm Hg, it fills the whole tube. When the pressure is further reduced (10<sup>-4</sup> mm Hg), the electric discharge passes between the electrodes and the tube begins to glow. This is due to the striking of some invisible rays from the cathode. These *rays which start from the cathode and move away from it, in straight lines are called cathode rays or cathode ray particles*. These rays can be further checked by making a hole in the anode and coating the tube behind anode with phosphorescent material like zinc sulphide. When these rays strike the zinc sulphide coating, a bright spot on the coating is developed.

#### Properties of Cathode Rays

- i. The cathode rays start from cathode and move towards the anode.
- ii. They are invisible, but their behaviour can be observed with the help of fluorescent or phosphorescent materials.
- iii. In the absence of electrical or magnetic field, these rays travel in straight lines.
- iv. In the presence of electric or magnetic field, the cathode rays behave similar to that of negatively charged particles. From this it is clear that the cathode rays consist of negatively charged particles called electrons.
- v. The characteristics of cathode rays (electrons) do not depend upon the material of electrodes and the nature of the gas present in the cathode ray tube.
- vi. These rays possess kinetic energy and hence can do mechanical work.
- vii. They can produce x-rays when incident on metals with high atomic mass.

## Charge to Mass Ratio of Electron

J.J. Thomson measured the ratio of electrical charge ( $e$ ) to the mass of electron ( $m_e$ ) by using cathode ray tube and applying electrical and magnetic field perpendicular to each other as well as to the path of electrons.

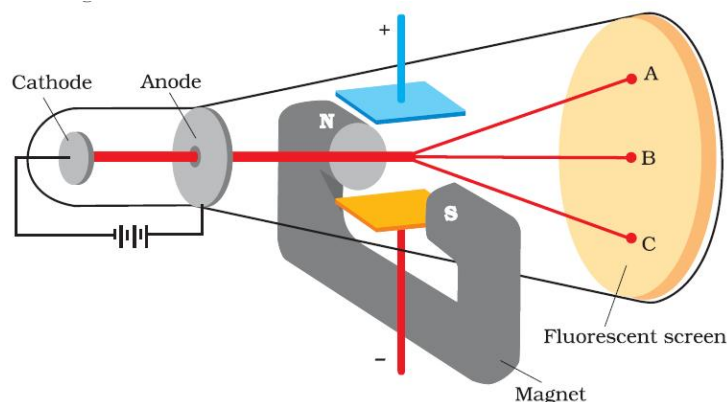

In the absence of electric or magnetic field, the cathode rays hit the screen at point B. When only electric field is applied, the electrons deviate from their path and hit the cathode ray tube at point A. Similarly, when only magnetic field is applied, electron strikes the cathode ray tube at point C. By carefully balancing the electrical and magnetic field strength, it is possible to bring back the electron beam to the point B. From the strength of electric and magnetic field, Thomson was able to calculate the value of  $e/m_e$  as:

$$e/m_e = 1.758 \times 10^{11} \text{ C kg}^{-1}$$

Where  $m_e$  is the mass of the electron in kg and  $e$  is the magnitude of the charge on the electron in coulomb (C). Charge on the Electron ( $e$ )

R.A. Millikan determined the charge on the electrons by a method known as 'oil drop experiment'. He found that the charge on the electron to be  $1.6022 \times 10^{-19} \text{ C}$ .

Mass of electron ( $m_e$ ). The mass of the electron ( $m_e$ ) was determined as follows:

$$e/m_e = 1.758 \times 10^{11} \text{ C kg}^{-1}$$

$$e = 1.6022 \times 10^{-19} \text{ C}$$

$$\begin{aligned} \text{Mass of electron } (m_e) &= 1.6022 \times 10^{-19} / 1.758 \times 10^{11} \\ &= 9.1 \times 10^{-31} \text{ kg} \end{aligned}$$

## Discovery of Protons

E. Goldstein modified the discharge tube experiment by perforating (with small holes) the cathode. After evacuating the tube and on applying high voltage, he found that some rays were emitted behind the cathode and moving in the opposite direction of cathode rays. These rays deflect to the negative plate of electric field. So they carry positive charge and were called anode rays or canal rays. Properties of Canal rays

The characteristics of canal rays are:

- i. They depend on the nature of gas present in the cathode ray tube. These are positively charged gaseous ions.
- ii. The charge to mass ratio of these particles depends on the nature of the gas.
- iii. Some of the positively charged particles carry a multiple of the fundamental unit of electric charge.
- iv. The behaviour of these particles in the magnetic or electrical field is opposite to that observed for cathode rays.
- v. They can produce heating effect and can do mechanical work.
- vi. They are invisible and can be observed with the help of fluorescent or phosphorescent materials.
- vii. They also travel in straight lines.
- viii. The smallest and lightest positive ion was obtained from hydrogen and was called proton.

## Discovery of Neutrons

Neutrons were discovered by Chadwick by bombarding a thin sheet of beryllium by  $\alpha$ -particles.

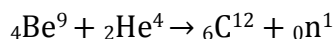

They are electrically neutral particles having mass slightly greater than that of the protons.

## Characteristics of sub-atomic particles

| Sub atomic particle | Symbol | Discoverer     | Absolute Charge (in Coulomb) | Relative charge | Mass/kg                  |
|---------------------|--------|----------------|------------------------------|-----------------|--------------------------|
| Electron            | e      | J J Thomson    | $-1.6022 \times 10^{-19}$    | -1              | $9.01 \times 10^{-31}$   |
| Proton              | p      | E. Goldstein   | $+1.6022 \times 10^{-19}$    | +1              | $1.6726 \times 10^{-27}$ |
| Neutron             | n      | James Chadwick | 0                            | 0               | $1.675 \times 10^{-27}$  |

Some important terms relating to Atomic structure

Atomic Number: It is the number of protons present in the nucleus or number of electrons present outside the nucleus. It is denoted by the symbol 'Z'.

Atomic number (Z) = nuclear charge or number of protons (p) = number of electrons (e)

Mass Number: It is the total number of protons and neutrons in atom. Or, it is the total number of nucleons in an atom.

It is denoted by 'A'. i.e. Mass number (A) = no. of protons (p) + no. of neutrons (n) or,  $A = p + n$

By knowing the atomic number and mass number,

we can calculate the number of neutrons as:  $n = A - Z$

If an element X has the atomic number Z and the mass number A, it is denoted as:  ${}_Z X^A$

### ISOTOPES, ISOBARS AND ISOTONES

Isotopes are atoms with same atomic number but different mass number. That is, they contain same number of protons but different number of neutrons. Almost all the elements have isotopes. All the isotopes of a given element have same chemical properties, but they differ in their physical properties. Hydrogen has three isotopes: Protium ( ${}_1\text{H}^1$ ), Deuterium ( ${}_1\text{H}^2$  or  ${}_1\text{D}^2$ ) and Tritium ( ${}_1\text{H}^3$  or  ${}_1\text{T}^3$ ). Among these, Protium is the ordinary hydrogen and Tritium is the radioactive isotope of Hydrogen.

Isobars are atoms of different elements having same mass number (same number of neutrons) but different atomic number. i.e. they have different number of protons but have equal sum of the protons and neutrons. e.g.  ${}_6\text{C}^{14}$  and  ${}_7\text{N}^{14}$   ${}_{18}\text{Ar}^{40}$  and

${}_{20}\text{Ca}^{40}$

| <i>Isotope</i> |   |   |   | <i>Isotones</i>     |   |   |   |
|----------------|---|---|---|---------------------|---|---|---|
| Isotope        | p | e | n | Isotones            | p | e | n |
| Protium        | 1 | 1 | 0 | ${}_6\text{C}^{14}$ | 6 | 6 | 8 |
| Deuterium      | 1 | 1 | 1 | ${}_7\text{N}^{14}$ | 7 | 7 | 8 |
| Tritium        | 1 | 1 | 2 | ${}_8\text{O}^{16}$ | 8 | 8 | 8 |

## ATOM MODELS

### Thomson's Model of Atom

J. J. Thomson proposed the first atom model, which is known as the plum pudding or raisin pudding or watermelon model. According to this model, an atom has a spherical shape in which the positive charge is uniformly distributed. The electrons are distributed in it, just like the seeds are distributed in a water melon or plums are distributed in a pudding. An important feature of this model is that the mass of the atom is assumed to be uniformly distributed over the atom. Also the total positive charge in an atom is equal to the total negative charge and hence the atom is electrically neutral.

### Rutherford's Nuclear Model of Atom

Rutherford proposed an atom model based on his  $\alpha$ -particle scattering experiment. He bombarded a very thin gold foil (approximately  $10^{-7}$ m thickness) with  $\alpha$ -particles. The Experiment: A stream of high energy  $\alpha$ -particles from a radioactive source was directed at a thin gold foil. The thin gold foil had a circular fluorescent zinc sulphide screen around it. Whenever  $\alpha$ -particles struck the screen, a tiny flash of light was produced at that point.

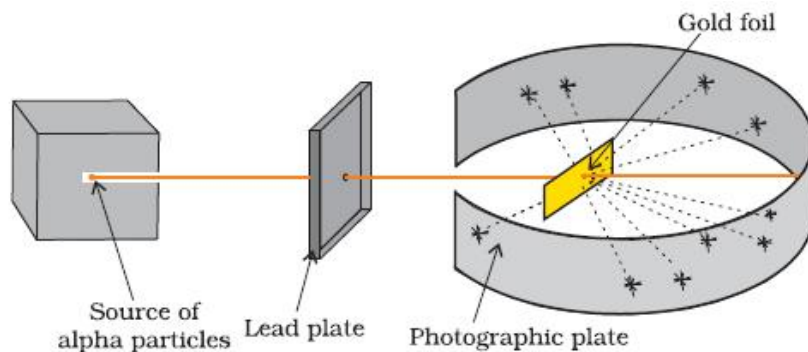

### Observations:

The important observations made by Rutherford are:

- i. Most of the  $\alpha$ - particles passed through the gold foil without any deviation.
- ii. A small fraction of the  $\alpha$ -particles was deflected by small angles.
- iii. A very few  $\alpha$ - particles ( $\sim 1$  in 20,000) bounced back, that is, were deflected by nearly  $180^\circ$ .



### Conclusions:

From the above observations, Rutherford made the following conclusions:

- i. Since most of the  $\alpha$ -particles passed through the foil without any deviation, most space in the atom is empty.
- ii. A few positively charged  $\alpha$ - particles were deflected. This is because the positive charge of the atom is concentrated in a very small volume at the centre called nucleus.
- iii. The volume occupied by the nucleus is negligibly small as compared to the total volume of the atom. The radius of the atom is about  $10^{-10}$  m, while that of nucleus is  $10^{-15}$  m.

On the basis of above observations and conclusions, Rutherford proposed the nuclear model (Planetary model) of atom. According to this model:

- i. All the positive charge and most of the mass of the atom are concentrated in an extremely small region called nucleus.
- ii. Electrons are revolving round the nucleus with a very high speed in circular paths called orbits.
- iii. Electrons and the nucleus are held together by electrostatic forces of attraction.

### Drawbacks or Limitations of Rutherford's atom model

- Rutherford's model cannot explain the stability of the atom.
- He cannot explain the electronic structure of atom.

### **Moseley's Experiment**

Henry Moseley's work reinforced the one-to-one identification of an atomic number  $Z$  with each element shortly after Rutherford's scattering hypothesis was validated by experiment (about 1913). (1887- 1915). He calculated the energy released when low-level electrons change orbitals using Bohr's atomic structure model. Because this energy has a strong relationship with an atomic number, the atomic number  $Z$  of an element may be established unambiguously by measuring the energy of its characteristic x-rays.

Moseley's law is an empirical law that applies to the distinctive x-rays that atoms release. Henry Moseley, an English physicist, discovered and published the law in 1913 by the

assumption that when the nucleus is screened by an unpaired electron that remains in the K-shell, the effective charge of the nucleus reduce by one is a common simplification.

**Apparatus:**

- The setup is quite simple. First, a  $^{57}\text{Co}$   $\gamma$ -ray source decays in such a way as to produce (among other things) several photons mainly consisting of 136 keV, 122 keV, and 14 keV  $\gamma$ -rays.  $^{57}\text{Co}$  undergoes electron capture, the product of which is a  $^{57}\text{Fe}$  nucleus in an excited state. Upon relaxation the  $^{57}\text{Fe}$  nucleus emits the  $\gamma$ -rays. The  $\gamma$ -rays strike the shielded target and knock electrons out from the target atoms. Other electrons drop to fill the hole created by the ejected electron and in the process emit characteristic x-rays.
- A proportional tube is used to detect the x-rays. It consists of a chamber filled with a noble gas (typically xenon). A thin positively charged wire runs along the axis. When an x-ray interacts inside the tube, it ejects electrons from the gas atoms. These are attracted to the wire, speed up enough to eject other electrons, and eventually cause a cascade of electrons to accelerate toward the wire. This charge pulse is amplified and recorded. The strength of the signal is proportional to the x-ray energy deposited in the tube; hence the name “proportional tube.”
- The multi-channel analyzer is used to determine x-ray energies. The multi-channel analyzer is mounted on a card inside the PC. A multi-channel analyzer measures all the voltage pulses from the proportional tube and sorts them into bins according to their strength. Each bin records pulses that fall within a set energy range and the bins form a sequential array so that the bin number N is proportional to the strength of the voltage pulse

**Experiment:**

- The detector will pick up on more than simply the x-rays. In addition, the detector will be hit by  $\gamma$ -rays directly from the Co source. More crucially, in the shielding, the sources will interact, resulting in a lead x-ray spectrum. Because the lead shielding is so much greater than the sample size, the signal may be masked. The data is gathered in two steps to remove the background. First, data is accumulated for predetermined amounts of time with the multi-channel analyzer on add. The sample is then withdrawn from the analyser, which is then set to subtract. For the same

period of time, data is accumulated. This removes background counts at the same pace as they were accumulated; resulting in data that only represents the sample's contribution.

- To begin, compare the x-ray spectra of six well-known materials: Al, Ti, Cu, Zr, Ag, and Te. Save the information in a file that which can access later.

### **Analysis:**

First, use six known samples to confirm Moseley's law. Because the energy of the characteristic x-ray should be proportional to  $(Z-\delta)^2$  and channel number  $N$  is proportional to  $E$ ,  $N$  is proportional to  $(Z-\delta)^2$ . As a result,  $N = kZ^2 - 2kZ\delta + k\delta^2$ . Plot  $N$  vs.  $Z$  for each of the six known samples. From this graph, find the optimal value for  $k$  and  $\delta$ . examine the spectra carefully and consider the sources of uncertainty in the data. Determine the uncertainties in  $\delta$  and  $k$  using an acceptable technique. Compare the peak positions of the unknowns to your results from the six known samples to determine  $Z$ .

## **WAVE NATURE OF ELECTROMAGNETIC RADIATION**

James Maxwell suggested that when electrically charged particle moves under acceleration, alternating electrical and magnetic fields are produced and transmitted. These fields are transmitted in the forms of waves called electromagnetic waves or electromagnetic radiation (emr). These are the radiations associated with electric and magnetic fields. E.g. light.

The important characteristics of these radiations are:

- i. The oscillating electric and magnetic fields are perpendicular to each other and both are perpendicular to the direction of propagation of the wave.
- ii. The electromagnetic waves do not require a medium for propagation and can move in vacuum.
- iii. There are many types of electromagnetic radiations, which differ from one another in wavelength (or frequency). These constitute electromagnetic spectrum. The important electromagnetic radiations in the increasing order of wavelength are:  
Cosmic rays, Gamma rays, X-rays, Ultra-violet rays, Visible light, Infra red rays, Microwaves, Radio waves.

- iv. All electromagnetic radiation travel through vacuum with a constant speed of  $3 \times 10^8$  m/s.

#### Some important terms relating to electromagnetic radiations

- Frequency ( $\nu$ ): It is defined as the number of waves that pass through a given point in one second. The SI unit for frequency is hertz (Hz, s<sup>-1</sup>).
- Wavelength ( $\lambda$ ): It is the distance between two adjacent crests or two adjacent troughs. Its unit is m or cm.
- Wave number ( $\bar{\nu}$ ): It is defined as the number of wavelengths per unit length. It is the reciprocal of wavelength. Its unit is m<sup>-1</sup> or cm<sup>-1</sup>.

The frequency ( $\nu$ ), speed of light ( $c$ ) and the wave length ( $\lambda$ ) are related to each other as:  $c = \nu \lambda$

#### **PARTICLE NATURE OF ELECTROMAGNETIC RADIATION: PLANCK'S QUANTUM THEORY**

Some of the experimental phenomenon like diffraction and interference can be explained by the wave nature of the electromagnetic radiation. But some phenomena like black body radiation, photoelectric effect, variation of heat capacity of solids with temperature, line spectra of atoms etc. could not be explained by wave nature of emr.

#### **BLACK BODY RADIATION**

An ideal body which emits and absorbs all frequencies of radiations is called a black body and the radiation emitted by such a body is called black body radiation. The frequency distribution of radiation emitted from a black body depends only on its temperature. At a given temperature, intensity of radiation emitted increases with decrease of wavelength, reaches a maximum value at a given wavelength and then starts decreasing. The phenomenon of black body radiation was first explained by Max Planck by his Quantum theory. According to this theory:

- ▲ Atoms and molecules could emit (or absorb) energy not in a continuous manner, but discontinuously in small packets of energy called quanta or photons.
- ▲ The energy ( $E$ ) of a quantum of radiation is proportional to its frequency ( $\nu$ )  
It is expressed by the equation,  $E = h\nu$  Where 'h' is known as Planck's constant and its value is  $6.626 \times 10^{-34}$  J s.

## PHOTOELECTRIC EFFECT

It is the phenomenon of ejection of electrons by certain metals (like potassium, rubidium, caesium etc.) when light of suitable frequency incident on them. The electrons ejected are called photoelectrons. This phenomenon was first observed by H.Hertz. The important characteristics of photoelectric effect are:

- i. The electrons are ejected from the metal surface as soon as the beam of light strikes the surface. i.e., there is no time lag between the striking of light beam and the ejection of electrons from the metal surface.
- ii. The number of electrons ejected is proportional to the intensity or brightness of light.
- iii. For each metal, there is a minimum frequency (known as threshold frequency  $\nu_0$ ) below which photoelectric effect is not observed.
- iv. The kinetic energy of the ejected electrons is directly proportional to the frequency of the incident light.

### *Explanation of photoelectric effect*

A satisfactory explanation to photoelectric effect was first given by Albert Einstein using Planck's Quantum theory. According to him, when a photon of sufficient energy strikes the metal surface, it transfers its energy to the electron of the atom of the metal instantaneously and the electron is ejected without any time lag. A part of the energy is used to eject the electron from the metal surface (i.e. to overcome the attractive force of the nucleus  $\times$ work function,  $h\nu_0$ ) and the other part is given to the ejected electron in the form of kinetic energy. Greater the energy possessed by the photon, greater will be transfer of energy to the electron and greater the kinetic energy of the ejected electron.

Since the striking photon has energy equal to  $h\nu$  and the minimum energy required to eject the electron is  $h\nu_0$  (also called work function,  $W_0$ ) then the difference in energy ( $h\nu - h\nu_0$ ) is transferred as the kinetic energy of the photoelectron.

Following the law of conservation of energy principle, the kinetic energy of the ejected electron is given by

$$K.E = h\nu - h\nu_0 \text{ (or), } h\nu = h\nu_0 + \frac{1}{2} m_e v^2$$

Where  $m_e$  is the mass of the electron and  $v$  is the velocity of the ejected electron.

A more intense beam of light contains larger number of photons, so the number of electrons ejected is also larger.

## DUAL BEHAVIOUR OF ELECTROMAGNETIC RADIATION

Electromagnetic radiations possess both particle and wave nature. This is known as dual nature of Electromagnetic Radiation.

### Atomic spectrum

When a ray of white light is passed through a prism, we get a series of coloured bands called spectrum. This spectrum is called continuous spectrum, because here violet merges into blue, blue into green and so on.

Similarly, when electromagnetic radiation interacts with matter, atoms and molecules may absorb energy and reach to a higher energy unstable state. To attain stability, they emit radiations in the form of spectrum. Such a spectrum is called atomic spectrum.

### Emission and Absorption Spectra

The spectrum of radiation emitted by a substance that has absorbed energy is called an emission spectrum. Atoms, molecules or ions that have absorbed radiation are said to be "excited". To produce an emission spectrum, energy is supplied to a sample by heating it or irradiating it and the wavelength (or frequency) of the radiation emitted is recorded.

An absorption spectrum is like the photographic negative of an emission spectrum. Here a continuum of radiation (like white light) is passed through a sample which absorbs radiation of certain wavelengths. The missing wavelengths leave dark spaces in the bright continuous spectrum. The study of emission or absorption spectra is referred to as spectroscopy.

The emission spectra of atoms in the gas phase do not form a continuous spectrum. The excited atoms emit light only at specific wavelengths with dark spaces between them. Such spectra are called line spectra or atomic spectra.

Line emission spectra are very useful in the study of electronic structure of atoms. Each element has a unique line emission spectrum. The characteristic lines in atomic spectra can be used in chemical analysis to identify unknown atoms in the same way as finger prints are used to identify people. So line emission spectra are also called finger print of atoms.

### Line Spectrum of Hydrogen

When an electric discharge is passed through gaseous hydrogen, the H<sub>2</sub> molecules dissociate and the energetically excited hydrogen atoms produced emit electromagnetic

radiation of discrete frequencies. The hydrogen spectrum consists of several series of lines named after their discoverers. The first five series of lines are Lyman, Balmer, Paschen, Brackett and Pfund series. Among these lines, the Balmer series is the only series that we can be visible (since it lies in the visible region of emr). Johannes Rydberg proposed an equation for finding the wave number of the different lines in Hydrogen spectrum.

The expression is:

$$\bar{\nu} = 1/\lambda = 109677 (1/n_1^2 - 1/n_2^2) \text{ cm}^{-1} \text{ Where } n_1 = 1, 2, 3, \dots \text{ and } n_2 = n_1 + 1, n_1 + 2, \dots$$

The different spectral lines, their  $n_1$  and  $n_2$  values and their spectral region are:

| Series   | Spectral region | $n_1$ | $n_2$      |
|----------|-----------------|-------|------------|
| Lyman    | Ultra violet    | 1     | 2,3,4....  |
| Balmer   | Visible         | 2     | 3,4,5....  |
| Paschen  | Infra red       | 3     | 4,5,6..... |
| Brackett | Infra red       | 4     | 5,6,7....  |
| Pfund    | Infra red       | 5     | 6,7,8..... |

### FRANCK–HERTZ EXPERIMENT

The Franck Hertz experiment was first studied in 1914 by James Franck and Gustav Hertz and presented to the German Physical Society. It was the first electrical measurement to show the quantum nature of atoms. The Franck Hertz experiment consisted of a vacuum tube designed to study the energetic electrons that flew through a thin vapour of mercury atoms. It was discovered that only a specific amount of an atom's kinetic energy would lose as the electrons collide with the mercury atom.

The main aim of this experiment to demonstrate the concept of quantisation of the energy levels according to the Bohr's model of an atom.

#### Theory:

The original experiment used a heated vacuum tube of temperature 115 °C with a drop of mercury of vapour pressure 100 Pa. Three electrodes, an electron-emitting hot cathode, a metal mesh grid, and an anode are attached to the tube. To draw the emitted electrons, the grid's voltage is made positive with respect to the cathode. The electric current measured in the experiment results from the movement of electrons from the grid to the anode. The electric potential at the anode is slightly more negative than the grid so the electrons have the kinetic energy the same as in the grid. The

Franck Hertz experiment was explained in terms of elastic and inelastic collisions between the electrons and the mercury atoms.

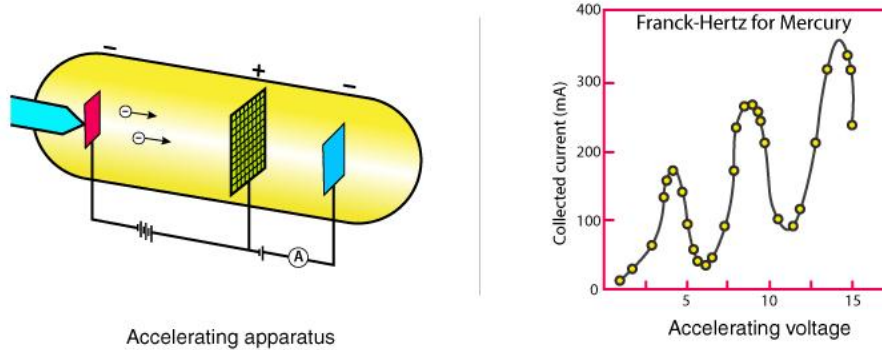

The graphs show the dependence of the electric current flowing out of the anode and the electric potential between the grid and the cathode. Following are the observations from the graph:

- With the steady increase in the potential difference, the current increases steadily through the tube.
- The current drops almost to zero at 4.9 volts.
- Again there is an increase in the current as the voltage increases to 9.8 volts.
- Again a similar drop is observed at 9.8 volts.

Energy absorption from electron collisions in the case of neon gas is seen. When the accelerated electrons excite the electrons in neon to upper states, they de-excite in such a way as to produce a visible glow in the gas region in which the excitation is taking place. There are about ten peak electron levels in the range of 18.3 to 19.5 eV. They de-excite by dropping to lower states at 16.57 and 16.79 eV. This energy difference gives the light in the visible range.

### Elastic Collision

An elastic collision is defined as an encounter between two bodies such that the total kinetic energy of the two bodies remains the same. During the collision, kinetic energy is first converted to potential energy related to repulsive force between the particles and converted back to kinetic energy. Rutherford back-scattering is an example of an elastic collision.

One-dimensional form of the elastic collision of particles 1 and 2:

$$\frac{1}{2}m_1u_1^2 + \frac{1}{2}m_2u_2^2 = \frac{1}{2}m_1v_1^2 + \frac{1}{2}m_2v_2^2$$

Where,

$m_1, m_2$  are the masses of particles 1 and 2

$u_1, u_2$  are the velocities of particles before the collision

$v_1, v_2$  are the velocities of particles after the collision



The magnitude of the velocities of the particles after the collision is given with two-dimensional form:

$$v_1' = v_1 \frac{\sqrt{m_1^2 + m_2^2 + 2m_1 m_2 \cos\theta}}{m_1 m_2} \quad v_2' = v_1 \frac{2m_1}{m_1 + m_2} \sin \frac{\theta}{2}$$

### Inelastic Collision

An inelastic collision is defined for the two bodies whose kinetic energies are not conserved due to internal friction. Macroscopic collisions result in effects, vibrations of the atoms and the deformation of the bodies. The formula of one-dimensional collision for particles a and b:

$$v_a = \frac{C_R m_b (u_b - u_a) + m_a u_a + m_b u_b}{m_a + m_b}$$

$$v_b = \frac{C_R m_a (u_a - u_b) + m_a u_a + m_b u_b}{m_a + m_b}$$

Where,

$v_a$  is the final velocity of the first object after impact

$v_b$  is the final velocity of the second object after impact

$u_a$  is the initial velocity of the first object before impact

$u_b$  is the initial velocity of the second object before impact

$m_a$  is the mass of the first object

$m_b$  is the mass of the second object

$C_R$  is the coefficient of restitution (ratio of final and initial relative velocities)

## **BOHR'S MODEL FOR HYDROGEN ATOM**

The general features of the structure of hydrogen atom and its spectrum was first explained by Niels Bohr. The important postulates of his theory are:

- i. The electron in the hydrogen atom can move around the nucleus in circular paths of fixed radius and energy. These paths are called orbits or stationary states or allowed energy states. These energy levels are numbered as 1,2,3 etc or as K, L, M, N, etc. These numbers are known as Principal quantum numbers.
- ii. The energy of an electron in an orbit does not change with time. However, when an electron absorbs energy, it will move away from the nucleus (i.e. to a higher energy level) and when it loses energy, it will move towards the nucleus (i.e. to a lower energy level).
- iii. The radius of orbits can be given by the equation:  $r_n = a_0 n^2$  where  $a_0 = 52.9 \text{ pm}$ .

Thus the radius of the first stationary state is 52.9 pm (called the Bohr radius). As  $n$  increases, the value of  $r$  will increase.

- iv. The energy of electron in an orbit is given by the expression:  $E_n = -R_H (1/n^2)$ , where  $n = 1, 2, 3, \dots$  and  $R_H$  is a constant called Rydberg constant. Its value is  $2.18 \times 10^{-18}$  J. The energy of the lowest state (the ground state) is given by  $E_1 = -2.18 \times 10^{-18}$  J. As the value of  $n$  increases, the energy of the electron also increases.
- v. The frequency of radiation absorbed or emitted when transition occurs between two stationary states that differ in energy by  $\Delta E$ , is given by:  $\nu = \Delta E/h = (E_2 - E_1)/h$
- Where  $E_1$  and  $E_2$  are the energies of lower and higher energy levels respectively. This expression is commonly known as Bohr's frequency rule.
- vi. The angular momentum of an electron is an integral multiple of  $h/2\pi$ . i.e.  $m_e v r = nh/2\pi$

Where  $m_e$  is the mass of electron,  $v$  is the velocity of electron and  $r$  is the radius of Bohr orbit.  $n = 1, 2, 3, \dots$ . Thus an electron can move only in those orbits whose angular momentum is an integral multiple of  $h/2\pi$ . So only certain fixed orbits are allowed.

#### Significance of negative energy of electron

When the electron is free from the influence of nucleus, its energy is taken as zero. In this situation, the electron is at the orbit with  $n = \infty$ . When the electron is attracted by the nucleus and is present in orbit  $n$ , the energy is emitted and its energy is lowered. That is the reason for the presence of negative sign in equation.

#### Explanation of Line Spectrum of Hydrogen

According to Bohr atom model, radiation is absorbed if the electron moves from lower energy to higher energy level and radiation is emitted if the electron moves from higher orbit to lower orbit. The energy gap between the two orbits is given by equation:

$$\Delta E = E_2 - E_1$$

$$\text{But } E_1 = -R_H/n_1^2 \text{ and } E_2 = -R_H/n_2^2$$

$$\begin{aligned} \text{Therefore, } \Delta E &= R_H [1/n_1^2 - 1/n_2^2] \\ &= 2.18 \times 10^{-18} [1/n_1^2 - 1/n_2^2] \end{aligned}$$

The frequency associated with the absorption and emission of the photon can be given as

$$\begin{aligned}
\nu &= \Delta E/h = R_H/h [1/n_1^2 - 1/n_2^2] \\
&= [2.18 \times 10^{-18} / 6.626 \times 10^{-34}] [1/n_1^2 - 1/n_2^2] \\
&= 3.29 \times 10^{15} [1/n_1^2 - 1/n_2^2]
\end{aligned}$$

$$\begin{aligned}
\text{The wave number } (\bar{\nu}) = 1/\lambda = \nu/c &= \{R_H/c\} [1/n_1^2 - 1/n_2^2] \\
&= \{3.29 \times 10^{15} / 3 \times 10^8\} [1/n_1^2 - 1/n_2^2] \\
&= 1.09677 \times 10^7 [1/n_1^2 - 1/n_2^2] \text{ m}^{-1} \\
&= 109677 [1/n_1^2 - 1/n_2^2] \text{ cm}^{-1}
\end{aligned}$$

In case of absorption spectrum,  $n_2 > n_1$  and the term in the bracket is positive and energy is absorbed. On the other hand, in case of emission spectrum  $n_2 > n_1$ ,  $\Delta E$  is negative and energy is released.

#### Limitations of Bohr Atom Model:

Bohr atom model could explain the stability and line spectra of hydrogen atom and hydrogen like ions (e.g.  $\text{He}^+$ ,  $\text{Li}^{2+}$ ,  $\text{Be}^{3+}$  etc). But it has the following limitations:

- i. It could not explain the fine spectrum of hydrogen atom.
- ii. It could not explain the spectrum of atoms other than hydrogen.
- iii. It was unable to explain the splitting of spectral lines in the presence of electric field (Stark effect) and in magnetic field (Zeeman effect).
- iv. It could not explain the ability of atoms to form molecules by chemical bonds.
- v. It did not consider the wave character of matter and Heisenberg's uncertainty principle.

### **DUAL BEHAVIOUR OF MATTER – DE BROGLIE'S EQUATION**

de Broglie proposed that like radiation, matter also exhibit dual behaviour i.e., both particle and wave like properties. This means that electrons should also have momentum as well as wavelength. He gave the following relation between wavelength ( $\lambda$ ) and momentum ( $p$ ) of a material particle.

$$\lambda = h/mv = h/p$$

Where  $m$  is the mass of the particle,  $v$  is the velocity and  $p$  is the momentum. The above equation is known as de Broglie's equation.

Just like electromagnetic radiations, an electron beam also undergoes diffraction. This is an evidence for the wave nature of electrons. An electron microscope works on the principle of wave nature of electron.

According to de Broglie, every moving object has a wave character. The wavelengths associated with ordinary objects are so short (because of their large masses) that their wave properties cannot be detected. The wavelengths associated with electrons and other subatomic particles (with very small mass) can be detected experimentally.

### DAVISSON GERMER EXPERIMENT

- In 1923 Louis de Broglie suggested that like radiation matter also possesses dual nature that are particle and wave. According to him a particle of mass  $m$  moving with velocity  $v$  always associated with a wave with wavelength  $\lambda = h/p$  here  $h$  is Planck's constant and  $p$  is momentum of the particle.
- In 1926 Walter Maurice Elsasser suggested that wave like nature of matter might be investigated by electron scattering experiment in crystalline solids.
- In 1927 Davisson and Germer proved that fast moving electrons show diffraction effect (property of waves) and calculated the wavelength of electron wave.
- In the same time G P Thomson also proved experimentally the wave nature of electrons.
- Davisson and Germer Experiment:
- The Davisson and Germer experiment confirmed the earlier hypothesis of de Broglie which demonstrated the wave nature of the electrons, this experiment confirms that electrons exhibit diffraction pattern when they are scattered from a crystal plane.

#### Davisson and Germer Apparatus:

Davisson Germer Experiment is carried out inside a vacuum Chamber. The key components are-

- i. Electron Gun – It contains a tungsten filament, which emits or produces electrons through a process called Thermionic Emission when heated to a specific temperature. The tungsten filament is coated with barium oxide.

- ii. ElectroStatic Particle Accelerator – two oppositely charged plates are provided with high voltage and are used to accelerate the electrons.
- iii. Collimator- this is a cylindrical shaped, perforated element, through which the emitted electrons are aimed towards the target- Nickel Crystal
- iv. Target- A nickel crystal is placed as a target, upon which the electrons are accelerated and then get deflected after striking the nickel crystal
- v. Secondary Electron Detector (SED) – a movable detector is placed at a certain angle ( $\theta$ ) from the nickel crystal. This detector collects the electrons deflected at different angles ( $\theta$ ) and cross-referenced with the intensity of the current produced in a sensitive galvanometer.

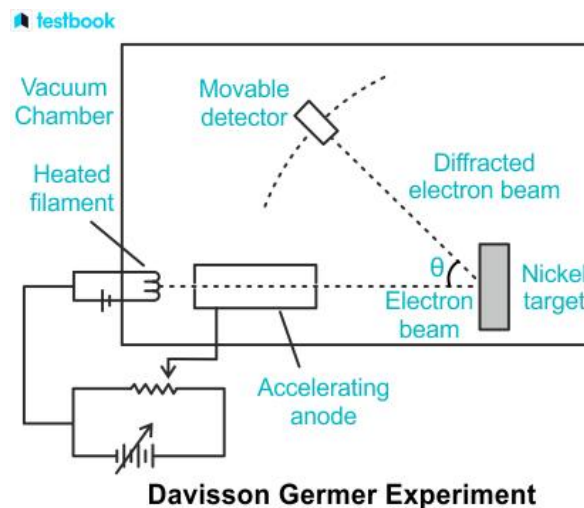

### Working of Davisson Germer Experiment

- First, the electrons are produced by heating the tungsten filament, coated with barium oxide, using a low-voltage power source. The process is called Thermionic Emission.
- Then, these emitted electrons are then accelerated and directed towards a nickel crystal by applying high voltage across the cylindrical accelerating anode and cathode with perforations. This, in turn, outputs a finely collimated beam of electrons.
- Once the electron hits the nickel crystal surface, they get deflected in different directions. The intensity of the deflected electrons in various directions depends mainly on the angle of the nickel crystal.

- A moving Secondary Electron Detector (SED) detects these deflected electrons. SED records the intensity of the deflected electrons in different directions.

#### Davisson and Germer Experiment Observations

SED is connected to a sensitive galvanometer. This converts the detected electrons into the current, and the intensity of the current is reflected in the gauge. The electron intensities are seen in multiple directions by moving the SED, and the direction or the angle ( $\theta$ ) with maximum and minimum intensities are recorded.

#### Outcomes of Davisson Germer Experiment

- Intensities of the deflected electrons are obtained by changing the angle ( $\theta$ ) of deflection
- The detector detects the particle nature of the electron. As a result, only the current will be detected by the detector.
- By changing the voltage across the accelerator plates, the acceleration of the electrons can be varied.
- The intensity of the dispersed electrons is not constant and provides a maximum and minimum value corresponding to the diffraction pattern.
- It is found that by changing the angle of scattering ( $\theta$ ), the intensity of the deflected electrons can be varied.
- In the experiment, it was followed that when the potential across the accelerating plates was adjusted between 44V to 68V and when the angle of deflection ( $\theta$ ) was at  $50^\circ$ , the maximum intensity (I) of the scattered electrons was observed at 54V.
- Due to the constructive interference of the deflected electrons, the maximum intensity (I) was observed from different layers of the nickel crystals with evenly spaced atoms.
- The wavelength of the deflected electrons was found using the electron diffraction method, and it was determined that the wavelength was 0.165 nm.

#### Co-relating Davisson Germer Experiment and de Broglie Relation

According to de Broglie,

$$\lambda = h / p$$

$$\lambda = h / \sqrt{2mE}$$

$$\lambda = h / \sqrt{2meV} \quad \dots\dots(1)$$

where, m= mass of an electron; e= charge on an electron and h= Plank's constant

Therefore for a given V, an electron will have a wavelength given by equation (1).

The following equation gives Bragg's Law:

$$n\lambda = 2d \sin(90^\circ - \theta/2) \quad \dots\dots(2)$$

For V = 54 V, we have

$$\lambda = 1.227 / \sqrt{54} = 0.167 \text{ nm}$$

### Proof of Davisson Germer Experiment

- In the Davisson Germer experiment, an assumption was made that deflected waves from two distinct atomic levels of the nickel crystal will have a constant phase difference.
- After deflection, the waves will either form constructive or destructive interference. Hence a diffraction pattern was formed, and the dual nature of the element was confirmed.

### **HEISENBERG'S UNCERTAINTY PRINCIPLE**

Werner Heisenberg proposed the uncertainty principle which is the consequence of dual behaviour of matter and radiation. It states that "it is impossible to determine simultaneously, the exact position and exact momentum (or velocity) of a moving microscopic particle like electron". Mathematically, it can be given as in equation:

$$\Delta x \cdot \Delta p \geq h/4\pi$$

$$\text{or, } \Delta x \cdot m\Delta v \geq h/4\pi$$

$$\text{or, } \Delta x \cdot \Delta v \geq h/4\pi m$$

Where  $\Delta x$  is the uncertainty in position and  $\Delta p$  (or,  $\Delta v$ ) is the uncertainty in momentum (or velocity) of the particle.

If the position of the electron is known with high degree of accuracy ( $\Delta x$  is small), then the velocity of the electron will be uncertain [ $\Delta v$  is large] and vice versa.

### Significance of Uncertainty Principle

Heisenberg Uncertainty Principle is significant only for motion of microscopic objects and is not applicable to macroscopic objects. According to this Principle, we cannot determine the exact position and momentum of an electron. Thus it rules out the existence of definite

paths or orbits of electrons. We can only say the probability of finding an electron at a given point.

### Reasons for the Failure of the Bohr Model

In Bohr model, electrons are moving in well defined circular orbits about the nucleus. The wave character of the electron is not considered in Bohr model. Further, an orbit is a clearly defined path and this path can completely be defined only if both the position and the velocity of the electron are known exactly at the same time. This is not possible according to the Heisenberg uncertainty principle. Therefore, Bohr model of the hydrogen atom not only ignores dual behaviour of matter but also contradicts Heisenberg uncertainty principle.

## **RULES FOR FILLING OF ELECTRONS IN VARIOUS**

Rules for Filling of electrons in various orbitals The filling of electrons into the orbitals of different atoms takes place according to the 3 rules - aufbau principle, Pauli's exclusion principle and the Hund's rule of maximum multiplicity.

### Aufbau principle:

The German word aufbau means 'build up'. The building up of orbitals means the filling up of orbitals with electrons. It states that the orbitals are filled in order of their increasing energies. In other words, electrons first occupy the lowest energy orbital and then to higher energy orbitals. This rule has two sub rules:

- The various orbitals are filled in the increasing order of their  $(n+l)$  value.
- If two orbitals have the same  $(n+l)$  values, the orbital with the lower  $n$  value is filled first.

The increasing order of orbitals is as follows: 1s, 2s, 2p, 3s, 3p, 4s, 3d, 4p, 5s, 4d, 5p, 6s, 4f, 5d, 6p, 7s...

### Pauli's Exclusion Principle

It states that no two electrons in an atom can have the same set of four quantum numbers. i.e. an orbital can accommodate a maximum of only 2 electrons with opposite spin. If 2 electrons have same values for  $n$ ,  $l$  and  $m$ , they should have different values for  $s$ . i.e. if  $s = +\frac{1}{2}$  for the first electron, it should be  $-\frac{1}{2}$  for the second electron.



### Hund's rule of maximum multiplicity

It states that electron pairing takes place only after partially filling all the degenerate orbitals. Orbitals having same energies are called degenerate orbitals. For example the electronic configuration of N is  $1s^2 2s^2 2p_x^1 p_y^1 p_z^1$  and not  $1s^2 2s^2 2p_x^2 p_y^1$ .

### Electronic Configuration of Atoms

The distribution of electrons into various orbitals of an atom is called its electronic configuration. The electronic configuration of different atoms can be represented in two ways.

- i.  $s^a p^b d^c$  ..... notation
- ii. Orbital diagram

The electrons in the completely filled shells are known as core electrons and the electrons in the outer most shell are called valence electrons.

### Stability of Completely Filled and Half Filled Subshells

For atoms having half filled or completely filled electronic configurations have extra stability compared to other atoms. This is due to their symmetrical distribution of electrons and greater exchange energy. For example, the electronic configuration of Cr is  $[\text{Ar}] 3d^5 4s^1$  and not  $3d^4 4s^2$ . This is because  $d^5$  represents a half filled configuration and has extra stability. Similarly for Cu the electronic configuration is  $[\text{Ar}] 3d^{10} 4s^1$  and not  $3d^9 4s^2$ .

## UNIT –II INTRODUCTION TO QUANTUM MECHANICS

### CLASSICAL MECHANICS

Classical mechanics, formulated by Isaac Newton, is obeyed by macroscopic particles such as planets and rigid bodies. Since the microscopic particles such as electrons, protons, atoms and molecules exhibit wave- Particle duality, they do not obey Newtonian dynamics. On the other hand, they obey quantum mechanics or wave mechanics, the laws of which were formulated by Born, Heisenberg and Jordan in 1925 and Schrodinger in 1926. The Schrodinger formulation is more familiar to chemist than the Born-Jordan-Heisenberg formulation. In classical mechanics, the state of a system is defined by specifying the forces acquiring on the particle and the exact position and velocity acquired by the particle as a result of these forces. It is impossible, however, to specify simultaneously the exact position as well as exact velocity in the case of microscopic particles. Therefore, while classical mechanics allows us to predict the exact paths taken by the particles of a macroscopic system, quantum mechanics gives the probabilities of the location of the particles of a microscopic system at various places in space.

As we shall see shortly, in quantum mechanics, the state of a system is defined by the state function or wave function  $\psi$ , which is a function of the co-ordinates of the particles of the system and is also a function of time. Thus, for a two-particle system, the wave function can be written as

$$\Psi=f(x_1, y_1, z_1, x_2, y_2, z_2)$$

Where  $x_1, y_1, z_1$  are the co-ordinates of particle 1 etc. For an n-Particle system, the equation governing the time-dependence of  $\psi$  is given by

$$\sum_{i=1}^n -\hbar^2/2m_i(\partial^2\psi^2/\partial x^2 + \partial^2\psi^2/\partial y^2 + \partial^2\psi^2/\partial z^2) + V(x_i, y_i, z_i, t) = i\hbar\partial\psi/\partial t$$

Where  $m_i$  is the mass and  $V$  is the potential energy of the particle.

The above equation is the celebrated time-dependent second order differential equation, Known as Schrodinger wave equation.

It may be noted that if the velocity of a microscopic particle is far less than the velocity of light, then quantum mechanics gives the same results as Newton's Classical mechanics. Also when the systems are in highly excited quantum states, classical mechanics and quantum mechanics tend to yield the same results.

## Atomic Orbitals

In 1913, Danish physicist Niels Bohr proposed what is known as the Bohr model of the atom. In the Bohr model, electrons exist at a fixed radius from a nucleus in a well-defined circular orbit. This was an accepted theory until the birth of quantum mechanics in the mid 1900s.

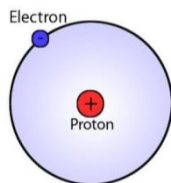

As physicists began to accept a quantum view of the world, a new model of the atom emerged based upon fact that mathematics predicted that energy is quantized within an atom.

*Quantization* is the process of taking continuous data and breaking it into discrete intervals, and the quantization of atomic energy meant that atoms could only have specific, discrete energy levels for their electrons to live on. What's more, the quantum model of an atom predicted that electrons were not confined to distinct orbits but instead they could exist in any place within one of these well-defined energy levels, and the clusters of electrons behaved like a single cohesive wave instead of like individual electrons. This **orbital wave** model of the electron led to the concept of **atomic orbitals** which is a concise term to describe all of the possible energy levels that can exist in a given atom.

## Wave-Mechanical Model of an Atom

In the early 1800s, a physicist named Thomas Young devised an experiment, now called *the double slit experiment*, to test the nature of light. In his experiment, Young shone a light at a screen with two rectangular slits in it. After the light passed through the slits it hit a viewing screen. To Young's surprise, the light on the viewing screen was not in a rectangular pattern to match the slits. Instead, Young saw an *interference pattern*, alternating dark and light patches, which could be explained if the light acted not as a particle but as a wave. If the light acted as a wave and the light waves exiting the slits were

out of phase with each other, an interference pattern would be created. Figure 2 is an example of an interference pattern.

Young's discovery was the beginning of quantum theory. In the mid-1990s, Louis de Broglie theorized that all matter exhibited particle-wave duality. His theory was proven not long after its birth by physicists Clinton Davisson and Lester Germer who accidentally discovered that a ray of electrons creates an interference pattern on nickel. At the same time as Davisson, Germer, and de Broglie, Erwin Schrodinger was mathematically figuring out how to describe the quantum behavior of waves, and the result is the *Schrodinger Equation* which is a partial differential equation that makes it possible to find the wave function of a particle.

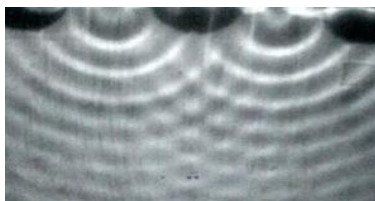

The discovery that electrons exhibited particle-wave duality led to a new theory of the atom called the **wave-mechanical model of the atom**. Quantum theory says that, until they are measured, particles do not have a definite position, and quantum theory deals in probabilities, not absolutes. For an atom, this means that the electrons do not orbit the nucleus in distinct circular trajectories as the Bohr model suggested. Rather, they can exist anywhere within a specified location surrounding the atom.

The **wave-mechanical model** of atomic theory has grown the idea of an electron cloud, and quantum theory predicts that electron clouds are not continuous. Instead, electron clouds are discrete energy levels that an atom can have, and, by the *Pauli exclusion principle*, identical electrons cannot inhabit the same space within these clouds. These attributes of the wave model of an atom dictate how electrons can fill the electron clouds. The following section explores how to fill electron clouds, called *electron orbitals*.

### **Electron Notation**

Electrons are elementary particles, and the only way to differentiate between two electrons is by their spin, which can either be spin up or spin down. Since the *Pauli exclusion principle* states that identical particles cannot inhabit the same space, the only

way for two electrons to be near each other in an atomic orbital is for one electron to be spin up and the other electron to be spin down.

When writing electron diagrams, the first step is to populate a given orbital with all spin up electrons; then populate the same orbital with spin down electrons. Once an entire orbital has been populated by electrons, move to the next orbital and continue as before until no electrons are left.

It is important to remember that electron orbitals represent the allowed energy levels within an atom and within each atomic orbital, electrons inhabit subshells. The first electron subshell that can be populated is  $1s$ . Successive subshells are populated to minimize the atom's energy. In order, the electron subshells fill by  $1s, 2p, 3s, 3p, 4s, 3d, 4p, 5s, 4d, 5p, 6s, 4f, 5d, 6p, 7s, 5f, 6d, 7p$ . Each subshell can hold a different number of electrons and each subshell and how many electrons it can hold is listed in the following table:

|                  |   |   |    |    |
|------------------|---|---|----|----|
| <b>Orbital</b>   | s | p | d  | f  |
| <b>Electrons</b> | 2 | 6 | 10 | 14 |

Using the table and the order, it is possible to write electron diagrams for any atom on the periodic table.

### *electron diagrams*

Magnesium is the twelfth element on the periodic table, so it has 12 electrons.

Bromine is the thirty fifth element on the periodic table. the electron diagram for Bromine element is a great example to illustrate that the electron subshells do not always fill by  $s$ , then  $p$ , then  $d$ , and so on

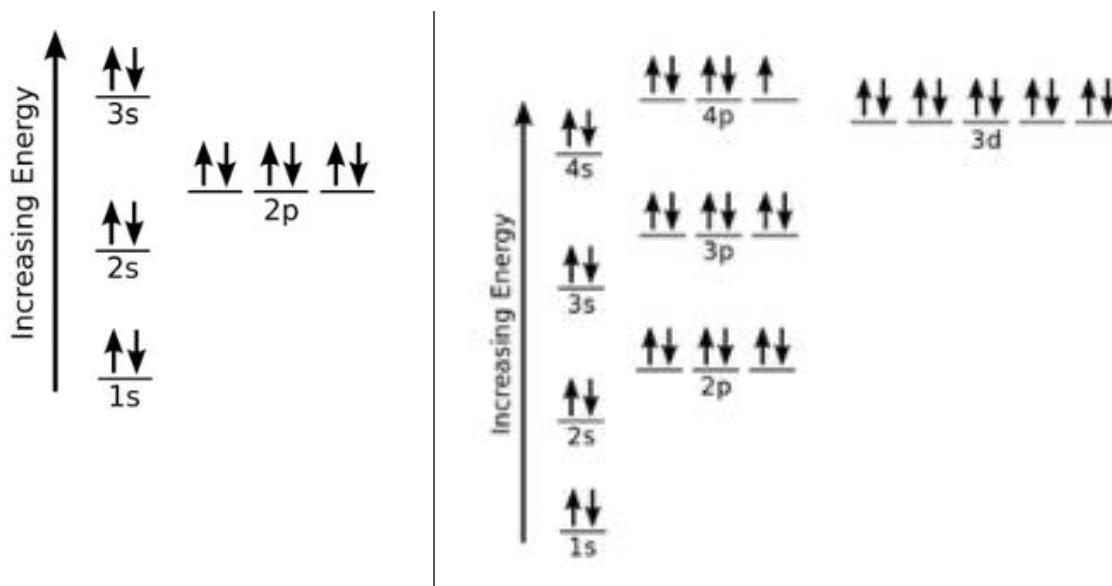

**DISTINCTION BETWEEN A BOHR ORBIT AND ORBITAL:**

| <b>ORBIT</b>  | <b>ORBITAL</b>   |
|---|--|
| An orbit is a fixed path on which electrons revolve around the nucleus.   | An orbital is the probable area of finding the maximum density of electrons in an atom.  |
| All orbits are circular in shape  | All orbital's are not circular in shape  |
| An orbit is a planar representation, i.e., a two dimensional representation.  | An orbital is a three dimensional representation.  |
| An orbit is non-directional in nature which means the shape of an atom cannot be described by an orbit.   | While an orbital can describe the shape of an atom thus is directional in nature.  |
| An orbit follows the principles of Bohr-Sommerfeld's theory.  | An orbital follows the theory of Heisenberg's Uncertainty Principle.   |
| An orbit can accommodate $2n^2$ electrons where n represents the number of the orbit or the shell. For example, K shell represents the 1st orbit, L shell represents the 2nd one. | An orbital can accommodate the maximum of two electrons only in its sub-levels. The s orbital has only one sub-level, so it can contain only 2 electrons. But the p orbital has 3 sub-levels and thus it can contain upto 6 electrons. |

**Postulates of Quantum mechanics**

The formulation of quantum mechanics or wave mechanics for the wave mechanical treatment of the structure of atom rests upon a few postulates which, for a system moving in one dimension, say the co-ordinate, are given below.

➤ **First Postulate:**

The state of a quantum mechanical system is completely specified by the wavefunction  $\psi(x,t)$

➤ **Second Postulate:**

The wave function  $\psi(x, t)$  and its first and second derivatives are continuous, finite and single-valued for all values of  $x$ . Also, the wave function  $\psi(x, t)$  is normalized. i.e

$$\int_{-\infty}^{+\infty} \psi^*(x, t)\psi(x, t)dx = 1$$

Where  $\psi^*$  is the complex conjugate of  $\psi$  formed by replacing  $i$  with  $-i$  wherever it occurs in the function  $\psi$ . ( $i = \sqrt{-1}$ )

➤ **Third Postulate:**

A physically observable quantity can be represented by a Hermitian Operator. An Operator  $A$  is said to be Hermitian if it satisfies the following condition:

$$\int \psi_i^* \hat{A} \psi_j dx = \int \psi_i^* (\hat{A} \psi_i)^* dx$$

Where  $\psi_i$ , and  $\psi_j$  are the wave functions representing the physical states of the quantum system, i.e a minute particle such as electron, proton, an atom or a molecule.

➤ **Fourth Postulates:**

The allowed values an observable  $A$  are the eigenvalues,  $a_i$ , in the operator equation

$$\hat{A} \psi_i = a_i \psi_i$$

Here  $\hat{A}$  is the operator for the observable and  $\psi_i$  is an eigen function of  $\hat{A}$  with eigen value  $a_i$ . In other words, measurements of the observable  $A$  yield the eigen value  $a_i$ .

➤ **Fifth Postulate:** The average value,  $\langle A \rangle$ , of an observable  $A$ , corresponding to the operator  $\hat{A}$ , is obtained from the relation

$$\langle A \rangle = \int_{-\infty}^{+\infty} \psi^* \hat{A} \psi dx$$

where the wave function  $\psi$  is assumed to be normalized in accordance with these equation. Thus the average value of the  $x$ - coordinate is given by

$$\langle A \rangle = \int_{-\infty}^{+\infty} \psi^* \hat{x} \psi dx$$

➤ **Sixth Postulate:**

The quantum mechanical operators corresponding to the observables are constructed by writing the classical expressions in terms of the variables and converting the expressions to the operators.

| Classical Variable | Quantum Mechanical operator | Operator                               | operation  |
|--------------------|-----------------------------|--|--|
| $x$                | $\hat{x}$                   | $x$                                    | Multiplication by $x$  |
| $p_x$              | $\widehat{p}_x$             | $-ih \frac{\partial}{\partial x}$      | Taking derivative with respect to $x$ and multiplying by $-ih$         |
| $x^2$              | $\widehat{x^2}$             | $x^2$                                  | Multiplication by $x^2$  |
| $p_x^2$            | $\widehat{p_x^2}$           | $-h^2 \frac{\partial^2}{\partial x^2}$ | Taking second derivative with respect to $x$ and multiplying by $-h^2$ |
| $t$                | $\hat{t}$                   | $t$                                    | Multiplication by $t$  |
| $E$                | $\widehat{E}$               | $-ih \frac{\partial}{\partial t}$      | Taking derivative with respect to $t$ and multiplying by $ih$          |

➤ **Seventh Postulate:** The wave function  $\psi(x,t)$  is a solution of the time dependent equation.

$$\widehat{H}\psi(x,t) = ih \frac{\partial \psi(x,t)}{\partial t} \quad \text{where } \widehat{H} \text{ is the Hamiltonian operator of the system.}$$

**Concept of probability and Schrodinger wave equation:**

It is evident from the earlier discussion that moving electrons behave both as particles and as a wave. If the electrons behave as a wave, there must be a wave equation to describe their behavior. Erwin Schrodinger, in 1926, gave a wave equation to describe the wave behavior of electrons in atoms and molecules. In Schrodinger wave model of an atom, the discrete energy levels or orbits proposed by Bohr are replaced by mathematical functions  $\psi$  which are related with the probability of finding electrons at various places around the nucleus.



The Schrodinger wave equation for an electron wave propagating in three dimensions in space is written as follows:

$$\frac{\partial^2 \psi}{\partial x^2} + \frac{\partial^2 \psi}{\partial y^2} + \frac{\partial^2 \psi}{\partial z^2} + \frac{8\pi^2 m}{h^2} (E - V) \psi = 0$$

$$\nabla^2 \psi + \frac{8\pi^2 m}{h^2} (E - V) \psi = 0$$

$$\nabla^2 = \frac{\partial^2 \psi}{\partial x^2} + \frac{\partial^2 \psi}{\partial y^2} + \frac{\partial^2 \psi}{\partial z^2}$$

$\nabla^2$  is known as Laplacian mathematical operator.

### Formulation of Schrodinger Wave Equation.

Schrodinger assumed the electron waves to be similar to the stationary waves, i.e., the waves produced by the vibrations of a stretched string. Consider such a wave being propagated in x direction. Let  $w$  be the amplitude of the wave at any point whose coordinate is  $x$  at time  $t$ . The equation for such a wave motion may be expressed as

$$\frac{\partial^2 w}{\partial x^2} = \frac{1}{u^2} \times \frac{\partial^2 w}{\partial t^2} \quad \text{-----1}$$

Where  $u$  is the velocity with which the wave propagates. The amplitude  $w$  in differential equation depends upon  $x$  and  $t$ .

Eq. 1 can be solved only if  $w$  can be written as a product of two mathematical functions, one of which depends on  $x$  only and other on  $t$  only, that is, if we can write  $w$  as

$$W = f(x) g(t) \quad \text{-----2}$$

For stationary waves, the function  $g(t)$  is represented by the expression

$$g(t) = A \sin(2\pi vt) \quad \text{-----3}$$

$\nu$  is the frequency of vibration and  $A$  is the maximum amplitude of the wave. Double differentiation of eq.3 with respect to time gives

$$\frac{\partial^2 g(t)}{\partial t^2} = -4\pi^2 \nu^2 A \sin(2\pi vt) = -4\pi^2 \nu^2 g(t) \quad \text{-----}$$

-----4

Similarly, double differentiation of Eq. 2 with respect to time and with respect to coordinate  $x$ , yields respectively

$$\frac{\partial^2 w}{\partial t^2} = f(x) \frac{\partial^2 g(t)}{\partial t^2} = -f(x) 4\pi^2 \nu^2 g(t) \quad \text{-----5}$$

$$\frac{\partial^2 w}{\partial x^2} = \frac{\partial^2 f(x)}{\partial x^2} g(t) \quad \text{-----6}$$

Substitute  $\frac{\partial^2 w}{\partial t^2}$  and  $\frac{\partial^2 w}{\partial x^2}$  both the Eq. 1

$$\frac{\partial^2 f(x)}{\partial x^2} g(t) = -\frac{1}{u^2} 4\pi^2 v^2 g(t) f(x) \quad \text{-----7}$$

$$\frac{\partial^2 f(x)}{\partial x^2} = -\frac{4\pi^2 v^2}{u^2} f(x) \quad \text{-----8}$$

But,  $u = v\lambda$ ;  $v/u = 1/\lambda$  hence in Eq.8, we get

$$\frac{\partial^2 f(x)}{\partial x^2} = -\frac{4\pi^2}{\lambda^2} f(x) \quad \text{-----9}$$

Eq. 9 is the equation for a one-dimensional stationary wave propagating in one direction only.

In three dimensional space,

$$\frac{\partial^2 \psi}{\partial x^2} + \frac{\partial^2 \psi}{\partial y^2} + \frac{\partial^2 \psi}{\partial z^2} = -\frac{4\pi^2}{\lambda^2} \psi \quad \text{-----10}$$

The above equation is applicable to all minute particles including electrons substituting the value of  $\lambda = h/mu$  in equation, we get

$$\frac{\partial^2 \psi}{\partial x^2} + \frac{\partial^2 \psi}{\partial y^2} + \frac{\partial^2 \psi}{\partial z^2} = -\frac{4\pi^2 m^2 u^2}{h^2} \psi \quad \text{-----11}$$

where  $m$  is the mass and  $u$  is the velocity of the particle. The total energy  $E$  of the particle is sum of its kinetic energy  $\frac{1}{2} mu^2$  and the potential energy  $V$ . Thus

$$E = \frac{1}{2} mu^2 + V \quad \therefore u^2 = 2(E-V)/m$$

Finally substituting the value of  $u^2$  we get Schrodinger wave Equation

$$\frac{\partial^2 \psi}{\partial x^2} + \frac{\partial^2 \psi}{\partial y^2} + \frac{\partial^2 \psi}{\partial z^2} = -\frac{4\pi^2 m^2}{h^2} \times \frac{2}{m} (E-V) \psi$$

$$\frac{\partial^2 \psi}{\partial x^2} + \frac{\partial^2 \psi}{\partial y^2} + \frac{\partial^2 \psi}{\partial z^2} + \frac{8\pi^2 m^2}{h^2} (E-V) \psi = 0 \quad \text{-----12}$$

### Probability density and significance of $\psi$

Heisenberg's uncertainty principle explains the exact position of the electron moving around the nucleus with a particular velocity. Therefore, in terms of the probability of its location in any given region. In other words, its position is defined by a probability function. Such a probability function will vary with the position of the region in space in which we want to find the probability of the existence of the electron. If  $\rho(x,y,z)$  is such a probability function, then the probability that the electron will be found in the small cubic volume element of dimension  $dx dy dz$ , is given by the product of  $\rho(x,y,z)$  and the volume of the small element, i.e. by  $\rho(x,y,z) dx dy dz$ . The small volume element, represented by a cube of

dimensions  $dx, dy, dz$  and surrounding the point  $\rho(x,y,z)$ . The small volume element  $dx dy dz$  around the point  $x,y,z$  is also written as  $\tau$ . The function  $\rho$  is also known as probability density. Imagine that the whole space is divided into a number of such volume elements. The total probability of finding the electron in the whole space will be given by the summation of all the terms of the type  $\rho dx dy dz$  or  $\rho d\tau$ . Since the electron has to be somewhere in space, the total probability must be equal to unity

$$\int_{-\infty}^{+\infty} \rho d\tau = \int_{-\infty}^{+\infty} \rho dx dy dz = 1$$

The concept of probability accounts for the fundamental law of nature that our knowledge of the position of a small moving particle can never be absolute.

### **Significance of $\psi$ and $\psi^2$**

An electron, from the probability concept, is considered as a three dimensional wave system extended around the nucleus and is represented by the symbol  $\psi$  which denotes the wave function of the electron;  $\psi$  itself has no physical significance and simply represents the amplitude of electron wave. Schrodinger's equation has several solutions for  $\psi$ , both real and imaginary. Some of the real values of  $\psi$  are appreciable while others are too small and hence neglected. If the value of  $\psi$  obtained as above is continuous, finite, single valued and electron probability in space related to  $\psi$  is equal to 1, then  $\psi$  is known as eigen function,  $\psi^2$  gives the probability of finding an electron of a given energy,  $E$  from place to place in a given region around the nucleus. Since,  $\psi$  often contains the imaginary quantity, but the probability of an electron in a given volume must be a real quantity, therefore the product  $\psi^*$  ( $\psi$  star) is used rather than  $\psi^2$  where  $\psi^*$  is complex conjugate of  $\psi$ . This product will always be real whereas  $\psi^2$  may be real or imaginary. If  $\psi$  is real quantity, then  $\psi$  and  $\psi^*$  both are same and hence  $\psi^2$  is also a real quantity and corresponds to probability density per unit volume.

### **SHAPES OF ATOMIC ORBITAL**

The shapes of atomic orbitals depend  $\theta$  and  $\phi$ . The values of  $\Theta_{l,m} \times \Phi_m$  for s-orbital ( $l=0, m=0$ ), p-orbital ( $l=1, m=0, \pm 1$ ), and d-orbitals ( $l=2, m=0, \pm 1, \pm 2$ ) can be obtained and correlated with the shapes of orbitals.

**For s-orbitals** ( $l=0, m=0$ ), the angular wave function  $\Theta_{0,0} \times \Phi_0$  is independent of the angles  $\theta$  and  $\phi$ , i.e. there is no angular wave function and hence orbitals have only one orientation and are spherically symmetrical over all the directions, hence have spherical shape as well as are non-directional. Thus, s-orbitals are usually represented by circles. Greater the value of  $n$  and higher the number of nodal points for s-orbital, larger is the size of orbital. The electron density in s-orbitals could be shown by concentric shades as follows:

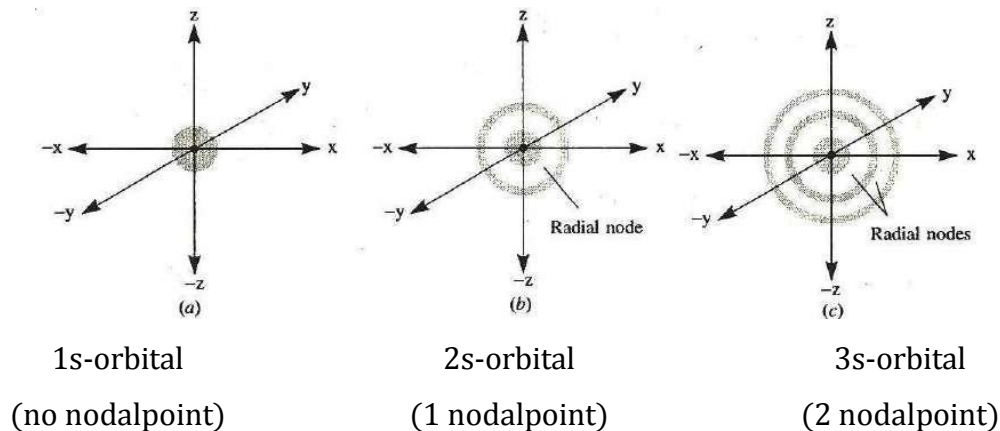

**For p orbitals** ( $l = 1, m = 0, \pm 1$ ), there are three values of  $m$  and therefore, there are three orientations of lobes of orbitals along Cartesian coordinates *viz.*  $p_x, p_y$  and  $p_z$ . The subscripts  $x, y$  and  $z$  indicate the axes along which orbitals are oriented. The three p-orbitals are similar in size, shape and energy but differ in orientation only. The angular wave function for these orientations is the product  $\Theta_m \times \Phi_m$ . For  $l=1, m=0$  orientation, the angular wavefunction  $\Theta_{1,0} \times \Phi_0$  is a real quantity and corresponds to  $p_z$  orbital which is dumb-bell shaped curve along  $z$ -axis in three dimensional space. For  $l=1, m=+1$  and  $l=1, m=-1$  orientations, angular wavefunctions are  $\Theta_{1,+1} \times \Phi_{+1}$  and  $\Theta_{1,-1} \times \Phi_{-1}$  which have imaginary quantities and are avoided. The real values are obtained by the normalised linear combinations (addition and subtraction) of angular wave functions. Thus, addition process, i.e.  $\Theta_{1,+1} \times \Phi_{+1} + \Theta_{1,-1} \times \Phi_{-1}$  gives normalised wave function corresponding to  $p_x$  orbital. In three dimensional space, this gives dumb-bell shaped curve along  $x$ -axis (Fig.1.4a). The subtraction process, i.e.  $\Theta_{1,+1} \times \Phi_{+1} - \Theta_{1,-1} \times \Phi_{-1}$  gives normalised wave function corresponding to  $p_y$  orbital which is again dumb-bell shaped curve in three dimensional space along  $y$ -axis.

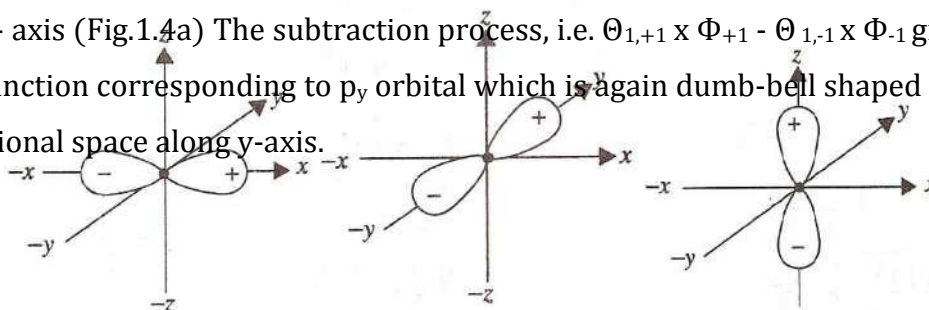

P<sub>x</sub>orbital

P<sub>y</sub>orbital

p<sub>z</sub>orbital

The (+) and (-) signs are algebraic signs of angular wave function and not the charge. The angular part of the wavefunction  $\psi(\Theta, \Phi)$  has (+) sign on one lobe and (-) sign on the opposite lobe although  $\psi^2(\Theta, \Phi)$  will be positive on both the lobes. Thus, for p-orbitals, the important points to be noted are:

- i. Since x, y and z axes are perpendicular to each other; the three p-orbitals are also perpendicular to each other.
- ii. Each of the three p-orbitals has two lobes on each side of the nucleus which is at the origin of the axes; hence the probability of finding the electron(s) in both lobes is equal. These lobes are separated by nodal planes passing through the nucleus. The electron density on the nodal plane is zero.
- iii. Greater the value of n (principal quantum number or the shell number), larger is the size of p orbital i.e. 3p orbital is larger in size than 2p orbital though the shapes of both the orbitals are the same. The energy of the three p-orbitals with the same value of n is same i.e. all the three p-orbitals are degenerate.

**For d-orbitals** ( $l=2, m=0, \pm 1, \pm 2$ ), five orientations (orbitals) are there corresponding to five values of m for  $l = 2$ . Depending on the permitted combinations of l and m, values for five d-orbitals, angular wavefunctions corresponding to different d-orbitals areas follows: For  $l = 2$  and  $m=0$ , the angular wave function  $e_{2,0} \times \Phi_0$  has a real value and corresponds to  $d_{z^2}$ -orbital. For  $l = 2$  and  $m = \pm 1$ , we have two angular wave functions,  $\Theta_{2,+1} \times \Phi_{+1}$  and  $\Theta_{2,-1} \times \Phi_{-1}$ . The values of these angular wavefunctions contain imaginary quantity and hence, these values are not accepted. The real and acceptable values are obtained from these by normalised linear combinations (addition and subtraction) of above functions. The addition process of above angular wave functions, i.e.  $\Theta_{2,+1} \times \Phi_{+1} + \Theta_{2,-1} \times \Phi_{-1}$  gives the wave function for  $d_{zx}$  (or  $d_{xz}$ ) orbital and subtraction process, i.e.  $\Theta_{2,+1} \times \Phi_{+1} - \Theta_{2,-1} \times \Phi_{-1}$ , gives the wave function for  $d_{yz}$ , orbital, for  $l = 2$  and  $m = \pm 2$ , we have two wave functions *viz.*  $\Theta_{2,+2} \times \Phi_{+2}$  and  $\Theta_{2,-2} \times \Phi_{-2}$ . Again the values of these wave functions contain imaginary quantity and hence are not accepted. Real and acceptable values are obtained by the normalised linear com

limination of the two angular wave functions. The addition process of above angular wave functions, i.e.,  $\Theta_{2,+2} \times \Phi_{+2} + \Theta_{2,-2} \times \Phi_{-2}$ , gives the wave function for  $d_{x^2-y^2}$  orbital and subtraction process i.e.,  $\Theta_{2,+2} \times \Phi_{+2} - \Theta_{2,-2} \times \Phi_{-2}$ , gives the wave subtraction for  $d_{xy}$  orbital. When these five angular wave functions for different orbitals obtained above are plotted in three dimensional space, we get the solid curves which give the orientations along the axes or in between the axes as shown below:

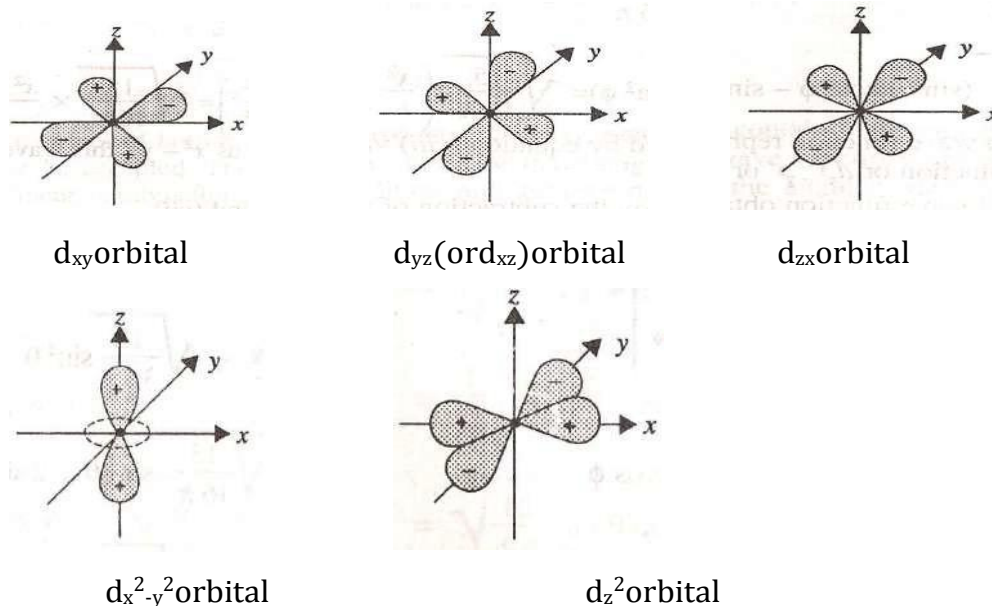

### MODERN PERIODIC TABLE

A periodic table is a table that organises all known elements into groups based on their properties, with like elements grouped together in the same vertical column and dissimilar elements separated.

#### Dobereiner's Triads

Dobereiner defined triads as groups of three elements in 1829. A triad's chemical characteristics were comparable. The atomic weight of the middle element was found to be approximately equal to the arithmetic mean of the other two elements when the elements in a trio were ordered in order of increasing atomic weights.

| Triad         | Iron           | Cobalt        | Nickel           | Mean of 1 <sup>st</sup> and 3 <sup>rd</sup> |
|---------------|----------------|---------------|------------------|---|
| Atomic weight | 55.85          | 58.93         | 58.71            | Nearly the same.                            |
| Triad         | <i>Lithium</i> | <i>Sodium</i> | <i>Potassium</i> | $7*39/2=23$                                 |

|               |                 |                  |               |                            |
|---------------|-----------------|------------------|---------------|----------------------------|
| Atomic Weight | 7               | 23               | 39            |                            |
| <i>Triad</i>  | <i>Chlorine</i> | <i>Bromine</i>   | <i>Iodine</i> | $35.5 \times 127 / 2 = 80$ |
| Atomic weight | 35.5            | 80               | 127           |                            |
| <i>Triad</i>  | <i>Calcium</i>  | <i>Strontium</i> | <i>Barium</i> | $40 \times 137 / 2 = 87.5$ |
| Atomic weight | 40              | 87.5             | 137           |                            |

### Newland's Law of Octaves

When the lighter elements were placed in order of increasing atomic weights, the properties of every eighth element were comparable to those of the first, as the eighth note of a musical scale, according to an English chemist named John Alexander Newlands in 1865. **Newlands' law of octaves** was named after this generalisation.

| sa<br>(do) | re<br>(re) | ga<br>(mi) | ma<br>(fa) | pa<br>(so) | da<br>(la) | ni<br>(ti) |
|------------|------------|------------|------------|------------|------------|------------|
| H          | Li         | Be         | B          | C          | N          | O          |
| F          | Na         | Mg         | Al         | Si         | P          | S          |
| Cl         | K          | Ca         | Cr         | Ti         | Mn         | Fe         |
| Co and Ni  | Cu         | Zn         | Y          | In         | As         | Se         |
| Br         | Rb         | Sr         | Ce and La  | Zr         | —          | —          |

### Lothar Meyer's Curve

**“The atomic masses of elements are periodic functions of their physical properties.”**

According to Lothar Meyer, atoms with similar properties occupy similar places in the atomic volume, as measured by the atomic mass curve.

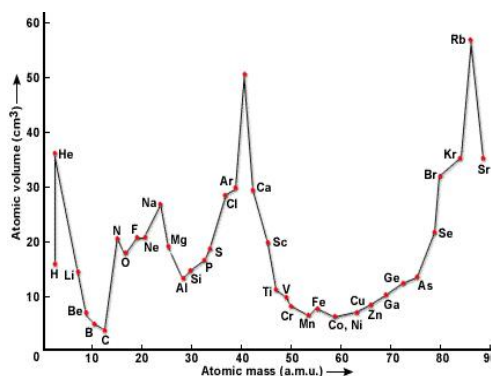

### Mendeleev's Periodic Law

Mendeleev organised atoms in a table's horizontal rows and vertical columns in order of increasing atomic weights, so that elements with comparable properties were grouped together in the same vertical column.

### Modern Periodic Law

Henry Moseley, an English physicist, discovered regularities in the distinctive X-ray spectra of the elements in 1913. Instead of a straight line between versus atomic mass, a plot of (where  $\nu$  is the frequency of X-rays emitted) against the atomic number ( $Z$ ) produced a straight line. As a result, Mendeleev's Periodic Law was altered correspondingly. The Modern Periodic Law can be stated as follows: The physical and chemical properties of elements are periodic functions of their atomic numbers.

### PERIODIC TABLE OF ELEMENTS

The image shows a standard periodic table with 18 groups and 7 periods. The title is "The Periodic Table of the Elements". The elements are color-coded by groups. Below the main table, there are two rows for Lanthanides (La to Lu) and Actinides (Ac to Lr).

### IUPAC Nomenclature of Elements

| Digit | Name | Abbreviation | Atomic Number | Name         | Symbol |
|-------|------|--------------|---------------|--------------|--------|
| 0     | Nil  | n            | 101           | Unnilunium   | Unu    |
| 1     | Un   | u            | 102           | Unnibium     | Unb    |
| 2     | Bi   | b            | 103           | Unniltrium   | Unt    |
| 3     | Tri  | t            | 104           | Unnilquadium | Unq    |
| 4     | Quad | q            | 105           | Unnilpentium | Unp    |
| 5     | Pent | p            | 106           | Unnilhexium  | Unh    |
| 6     | Hex  | h            | 107           | Unnilseptium | Uns    |
| 7     | Sept | s            | 108           | Unniloctium  | Uno    |
| 8     | Oct  | o            | 109           | Unnilennium  | Une    |
| 9     | Enn  | e            | 110           | Ununnillium  | Uun    |



## Properties of an Element

### **Atomic Radius**

Atomic radius is generally stated as being the total distance from an atom's nucleus to the outermost orbital of electron. In simpler terms, it can be defined as something similar to the radius of a circle, where the center of the circle is the nucleus and the outer edge of the circle is the outermost orbital of electron. So, depending on the atoms' surroundings, multiple forms of atomic radius can be utilized, such as covalent radius, van der Waals' radius, and metallic radius.

#### i. Covalent Radius

The covalent radius of a molecule is half the distance between the nuclei of two identical atoms linked by a single covalent bond.

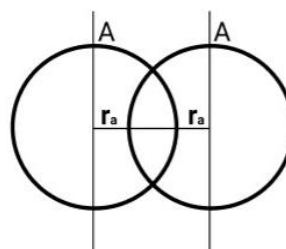

**So, covalent radius for A-A**

$$r_A = d_{A-A} / 2$$

**If covalent bond is formed between two different elements then**

$$d_{A-B} = r_A + r_B - 0.09(\chi_A - \chi_B)$$

Where,  $\chi_A$  and  $\chi_B$  are electro negativities of A and

#### ii. Vander Waal's Radius

In the solid state, it is half of the inter nuclear distance between adjacent atoms of two neighbouring molecules.

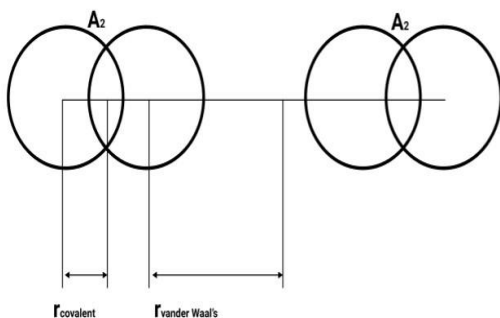

#### iii. Metallic Radius (Crystal Radius)

In the metallic crystal lattice, it is half the distance between the nuclei of two neighbouring metal atoms. So metallic radius for A-A:

$$d = r_A + r_A$$

$$r_A = d / 2$$

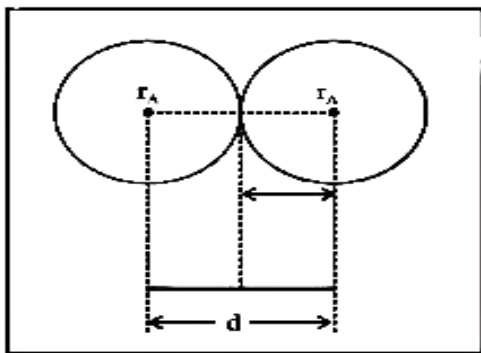

### *Variation of Atomic Radii in the Periodic Table Atomic Radii*

As we move from left to right in a period, the covalent and vander Waals radii generally decrease with increasing atomic number.

#### iv. Ionic Radius

A cation is formed when an electron is removed from an atom, and an anion is formed when an electron is gained. In general, element ionic radii follow the same pattern as atomic radii. Because it has fewer electrons than its parent atom, a cation is smaller, but its nuclear charge remains the same. Because the addition of one or more electrons causes enhanced electron repulsion and a decrease in effective nuclear charge, the size of an anion will be bigger than that of The parent atom. The ionic radius of the fluoride ion ( $F^-$ ) is 136pm, while the atomic radius of fluorine is just 64 pm. The atomic radius of sodium, on the other hand, is 186 pm, whereas the ionic radius of  $Na^+$  is 95 pm.

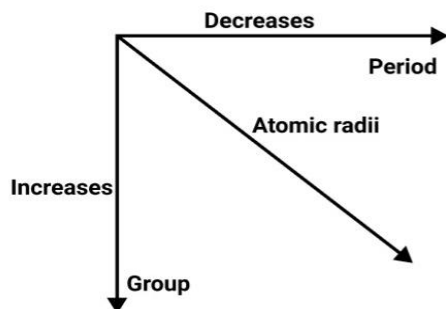

#### Isoelectronic Species:

Isoelectronic species have the same number of Electrons as each other.  $O^{2-}$ ,  $F$ ,  $Na^+$ , and  $Mg^{2+}$ , for example, all have the same number of electrons. Because of their various nuclear charges, their radii would be varied. Because the electrons are more attracted to the nucleus, the cation with the higher positive charge will have a smaller radius. The radius of

an anion with a higher negative charge will be larger. The net repulsion of the electrons will outweigh the nuclear charge in this situation, causing the ion to expand in size.

i. Ionization Energy

- Ionization energy is the least amount of energy required to remove an electron from the outermost orbit of an isolated atom in the gaseous state.

$IE_1, IE_2, IE_3$  and  $IE_4$  are successive ionization energies.

$IE_4 < IE_3 < IE_2 < IE_1$  or  $\Delta_i H_4 < \Delta_i H_3 < \Delta_i H_2 < \Delta_i H_1$

- *Variation of Ionisation Energy in Periodic Table*

- ▲ Variation along a period: The value of ionisation enthalpy grows from left to right over time, with intervals where the atoms' configurations are somewhat stable. Increased nuclear charge and decreased atomic radii are simple explanations for the observed trends. Both factors enhance the force of attraction towards the nucleus, requiring more and more energy to remove the electrons, resulting in higher ionisation enthalpies.

- ▲ Variation along a period: The atomic size grows steadily as the group progresses due to the addition of one additional primary energy shell at each consecutive element. As a result, the ionization enthalpy value drops as the force of attraction towards the valence electrons decreases.

- Units of I.E / I.P

It is expressed in electron volts(eV), kilocalories per mole ( $\text{kcal mol}^{-1}$ ), or kilo joules per mole ( $\text{kJ mol}^{-1}$ ) units. The energy gained by an electron while travelling under a potential difference of one volt is known as an electron volt.

- The ionisation energy of an atom or an ion increases as the size of the atom or ion decreases.
- As the screening effect decreases, the ionization energy increases. With the increased nuclear charge, ionization energy rises. If an atom's orbitals are half filled or entirely filled, the ionization energy rises. The penetrating power of orbitals is in the order:  $s > p > d > f$

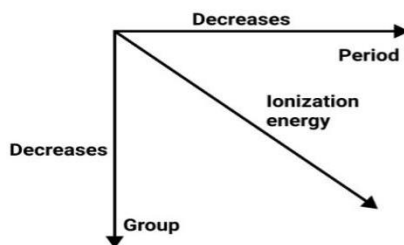

## ii. Electron Gain Enthalpy

- The Electron Gain Enthalpy is the enthalpy change that occurs when an electron is added to a neutral gaseous atom ( $X$ ) to turn it into a negative ion. The case with which an atom adds an electron to create an anion is measured by the electron gain enthalpy.  $X(g) + e^- \rightarrow X^-(g)$
- The process of adding an electron to an atom can be either endothermic or exothermic, depending on the element. When an electron is added to an atom, energy is dissipated, and the electron gain enthalpy is negative for many elements. Because they can achieve stable noble gas electrical configurations by taking up an electron, group 17 elements (the halogens) have exceptionally high negative electron gain enthalpies. Noble gases, on the other hand, have substantial positive electron gain enthalpies because the electron must enter the next higher main quantum level, result in an electronic configuration that is exceedingly unstable.
- Variation of Electron Gain Enthalpy
  - ▲ Variation along a period: In a period, the electron gain enthalpy shifts from left to right, becoming increasingly negative. As the atomic number increases over time, the size of the nucleus shrinks and the nuclear charge increases. Due to the larger force of attraction by the nucleus for the incoming electron, both of these considerations favour the addition of an extra electron.
  - ▲ Variation along with a group: Going down from top to bottom in a group, the electron gain enthalpies become less negative. This is owing to the fact that as you move down a group, your size grows. In comparison to the other factor, which is an increase in nuclear charge, this factor is more important.

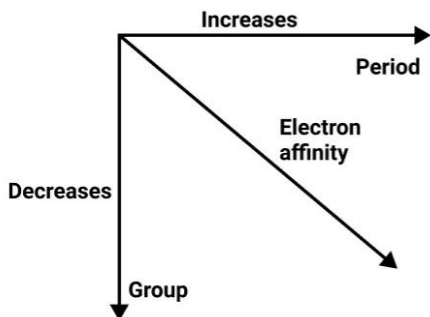

### iii. Electronegativity

- Electronegativity refers to an atom's inclination to draw the shared pair of electrons towards itself. The electronegativity of fluorine is 4.0, according to Pauling, and the electronegativity of other elements can be derived as:
- **Mulliken:**  $\text{Electronegativity} = \frac{\text{IP} + \text{EA}}{2}$   
 where, IP is the Ionization potential and EA is the Electron Affinity. If IP and EA are taken as electron volt:
- $\text{Percentage ionic character} = 16(\chi_A - \chi_B) + 3.5(\chi_A - \chi_B)^2$
- If the difference in the electronegativity of combining atoms is 1.7, the bond is 50% covalent and 50% ionic. The oxide takes on a basic character when the difference between the electronegativities of oxygen and the element is quite large.

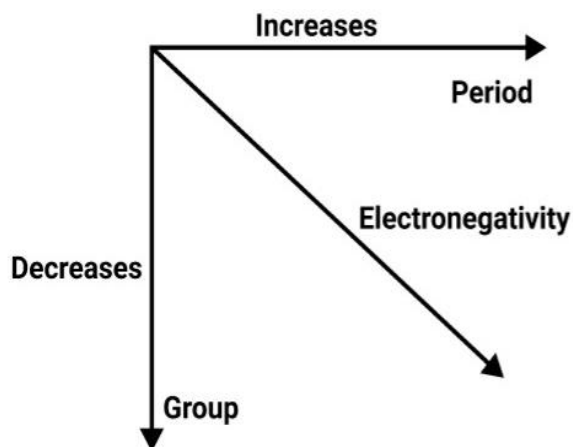

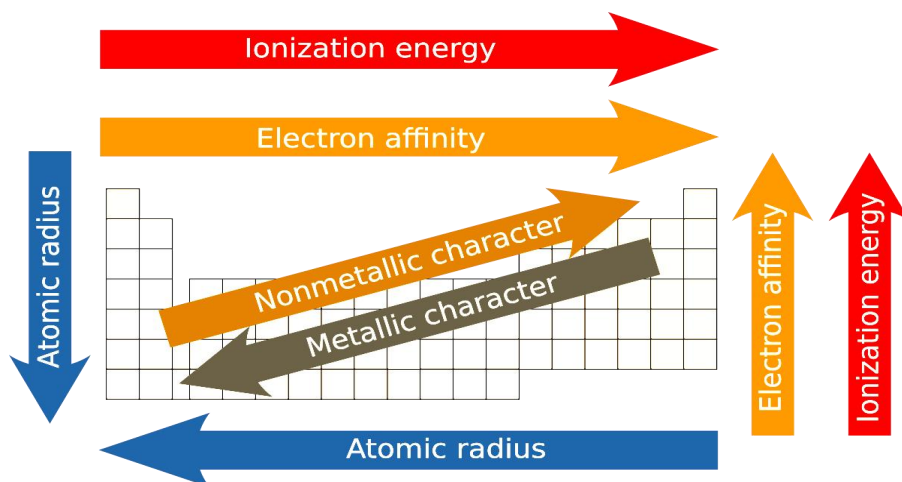

iv. Periodic Trends in Chemical Properties Periodicity of Valence or Oxidation States

- Valence electrons are the electrons found in an atom's outermost shell, and the number of these electrons determines the atom's valence or valency. Because of this, the atom's outermost shell is also known as the valence shell, and the orbitals that make up the valence shell are known as valence orbitals. The valence of an atom is generally equal to either the number of valence electrons (*s*- and *p*- block elements) or eight minus the number of valence electrons in representative elements.

|                                    |   |   |    |    |     |     |     |     |
|------------------------------------|---|---|----|----|-----|-----|-----|-----|
| <b>Group</b>                       | 1 | 2 | 13 | 14 | 15  | 16  | 17  | 18  |
| <b>Number of Valence electrons</b> | 1 | 2 | 3  | 4  | 5   | 6   | 7   | 8   |
| <b>Valence Shell</b>               | 1 | 2 | 3  | 4  | 3,5 | 2,6 | 1,7 | 0,8 |

- Transition and inner transition elements, on the other hand, have varying valence due to the presence of not just valence electrons but also *d*- or *f* electrons. Their most common valences, however, are 2 and 3.

▲ **Variation along a period:**

The number of valence electrons grows from 1 to 8 as move through a period from left to right. However, the valence of elements in relation to hydrogen or oxygen increases from 1 to 4 before decreasing to zero. The more electro negative oxygen receives two electrons from each of the two sodium atoms in the production of the  $Na_2O$  molecule, giving it an oxidation state of  $-2$ . Sodium, on the other hand, loses one electron to oxygen and has an Oxidation state of  $+1$  because

of its valence shell electrical configuration of  $3s^1$ . Thus, an element's oxidation state in a compound can be described as the charge obtained by its atom as a result of the electronegativity of the other atoms in the molecule.

▲ **Variation within a group:**

Because the number of valence electrons remains constant as we proceed down the group, all elements in a group have the same valence. All elements in group 1 (alkali metals), for example, have valence one, whereas all elements in group 2 (alkaline earth metals) have valence two. Noble gases of group 18 have zero valences, which means their valence is zero because they are chemically inert.

**Anomalous Properties of Second Period Elements:**

Some elements from the second period appear to be identical to elements from the third period when put diagonally next to each other while belonging to separate groups. Lithium (group 1), for example, resembles magnesium (group 2), while beryllium (group 2) resembles aluminium (group 13), and so on. A diagonal relationship refers to the resemblance in attributes of elements that are arranged diagonally next to each other.

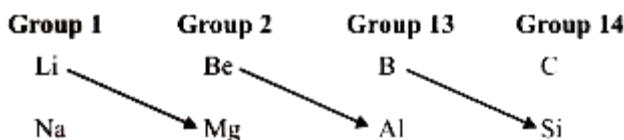

The elements' unusual behaviour is caused by their short size, huge charge/radius ratio, and strong electronegativity. Furthermore, the first member of the group only has four valence orbitals ( $2s$  and  $2p$ ) accessible for bonding, whereas the second member of the group has nine ( $3s$ ,  $3p$ ,  $3d$ ). As a result, the maximum covalency of the first member of each group is 4 boron can only create  $BF_3$ , whereas the other members of the groups can expand their valence shell to include more than four pairs of electrons, aluminium can form  $AlF_3$ . Furthermore, as compared to later members of the same groups, the first member of p-block elements has a larger potential to make p-p multiple bonds to itself

### **Applications of electronegativities**

Electronegativities have very wide range of applications. Some of the important applications are given below.

- Calculation of partial ionic character of a covalent bond.
- Calculation of enthalpies of formation of compounds
- Calculation of bond length
- Explanation for bond angles
- Rationalisation of reaction mechanism
- Explanation of diagonal relationship
- Types of bonds



## UNIT III- STRUCTURE AND BONDING – I

### IONIC BOND

#### Lewis electron dot diagram

A Lewis electron dot diagram (or electron dot diagram, or a Lewis diagram, or a Lewis structure) is a representation of the valence electrons of an atom that uses dots around the symbol of the element. The number of dots equals the number of valence electrons in the atom. These dots are arranged to the right and left and above and below the symbol, with no more than two dots on a side. The order in which the positions and the side are used does not matter. For example, the Lewis electron dot diagram for hydrogen is simply

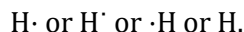

| Atom             | electrons          | Valence electrons | Lewis electron dot diagram                                   |
|------------------|--------------------|-------------------|--|
| <u>Helium</u>    | $1s^2$             | 2                 | $\text{He} \cdot \cdot$                                      |
| <u>Lithium</u>   | $1s^2, 2s^1$       | 1                 | $\text{Li} \cdot$  |
| <u>Beryllium</u> | $1s^2, 2s^2$       | 2                 | $\text{Be} \cdot \cdot$                                      |
| <u>Boron</u>     | $1s^2, 2s^2, 2p^1$ | 3                 | $\begin{array}{c} \cdot \cdot \\ \text{B} \cdot \end{array}$ |

It has three valence electrons. The third electron will go on another side of the symbol

|               |                    |   |  |
|---------------|--------------------|---|--|
| <u>Carbon</u> | $1s^2, 2s^2, 2p^2$ | 4 | $\begin{array}{c} \cdot \cdot \\ \cdot \text{C} \cdot \end{array}$ |
|---------------|--------------------|---|--|

There are four valence electrons, two in the 2s subshell and two in the 2p subshell. As usual, two dots together on one side, to represent the 2s electrons. other two dots for the two p electrons on different sides

|                 |                    |   |  |
|-----------------|--------------------|---|--|
| <u>Nitrogen</u> | $1s^2, 2s^2, 2p^3$ | 5 | $\begin{array}{c} \cdot \cdot \\ \cdot \text{N} \cdot \cdot \end{array}$ |
|-----------------|--------------------|---|--|

There are five valence electrons, two in the 2s subshell and three in the 2p subshell. As usual, two dots together on one side, to represent the 2s electrons with three p electrons, on each of the three remaining sides

|               |                    |   |  |
|---------------|--------------------|---|--|
| <u>Oxygen</u> | $1s^2, 2s^2, 2p^4$ | 6 | $\begin{array}{c} \cdot \cdot \\ \cdot \text{O} \cdot \cdot \end{array}$ |
|---------------|--------------------|---|--|

Fluorine     $1s^2, 2s^2, 2p^5$     7



## Ionic bond

The ions are formed by losing electrons to make cations, or by gaining electrons to form anions. Most of the ions that form have eight electrons in their valence shell either atoms gain enough electrons to have eight electrons in the valence shell and become the appropriately charged anion, or they lose the electrons in their original valence shell; the lower shell, now the valence shell, has eight electrons in it, so the atom becomes positively charged. For whatever reason, having eight electrons in a valence shell is a particularly energetically stable arrangement of electrons. The octet rule explains the favorable trend of atoms having eight electrons in their valence shell. When atoms form compounds, the octet rule is not always satisfied for all atoms at all times, but it is a very good rule of thumb for understanding the kinds of bonding arrangements that atoms can make.

It is not impossible to violate the octet rule. Consider sodium: in its elemental form, it has one valence electron and is stable. It is rather reactive, however, and does not require a lot of energy to remove that electron to make the  $\text{Na}^+$  ion. We could remove another electron by adding even more energy to the ion, to make the  $\text{Na}^{2+}$  ion. However, that requires much more energy than is normally available in chemical reactions, so sodium stops at a 1+ charge after losing a single electron. It turns out that the  $\text{Na}^+$  ion has a complete octet in its new valence shell, the  $n = 2$  shell, which satisfies the octet rule. The octet rule is a result of trends in energies and is useful in explaining why atoms form the ions that they do.

Now consider an Na atom in the presence of a Cl atom. The two atoms have these Lewis electron dot diagrams and electron configurations:

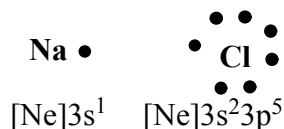

For the Na atom to obtain an octet, it must lose an electron; for the Cl atom to gain an octet, it must gain an electron. An electron transfers from the Na atom to the Cl atom: resulting in two ions—the  $\text{Na}^+$  ion and the  $\text{Cl}^-$  ion:

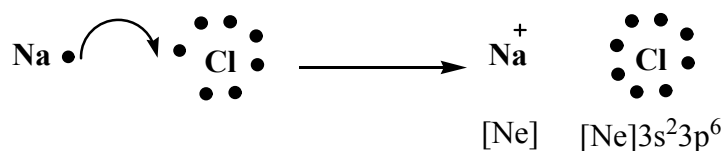

Both species now have complete octets, and the electron shells are energetically stable. From basic the opposite charges attract. This is what happens to the Na<sup>+</sup> and Cl<sup>-</sup> ions:

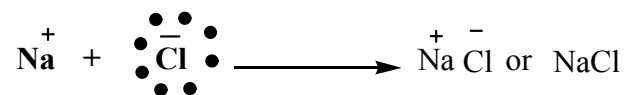

where we have written the final formula (the formula for sodium chloride) as per the convention for ionic compounds, without listing the charges explicitly. ***The attraction between oppositely charged ions is called an ionic bond***, and it is one of the main types of chemical bonds in chemistry. Ionic bonds are caused by electrons transferring from one atom to another.

In electron transfer, the number of electrons lost must equal the number of electrons gained.

#### Properties of ionic compounds

The properties of ionic compounds follow from the orderly crystal lattice arrangement of tightly bonded charged particles that make them up. Ionic compounds tend to have high melting and boiling points, because the attraction between ions in the lattice is very strong. Moving ions out of the lattice disrupts the structure, so ionic compounds tend to be brittle rather than malleable. Ionic compounds do not conduct electricity in the solid state because ions are not free to move around the lattice; however, when ionic compounds are dissolved, they may dissociate into individual ions which move freely through the solution and therefore conduct electricity well.

Ionic bonding is the attraction between positively- and negatively-charged ions. These oppositely charged ions attract each other to form ionic networks, or lattices. Electrostatics explains why this happens: opposite charges attract and like charges repel. When many ions attract each other, they form large, ordered, crystal lattices in which each ion is surrounded by ions of the opposite charge. Generally, when metals react with non-metals, electrons are transferred from the metals to the non-metals. The metals form positively-charged ions and the non-metals form negatively-charged ions.

Ionic compounds are held together by electrostatic forces, which are described in classical physics by Coulomb's Law. According to this law, the energy of the electrostatic

attraction (E) between two charged particles is proportional to the magnitude of the charges ( $Q_1$  and  $Q_2$ ) and inversely proportional to the internuclear distance between the particles ( $r$ ):

$$E \propto (Q_1 Q_2)/r$$

The energy of attraction (E) is a type of potential energy, since it is based on the position of the charged particles relative to each other. If the two particles have opposite charges (as in ionic compounds), the value of (E) will be negative, meaning that energy is released by bringing the particles together that is, the particles naturally attract each other. According to Coulomb's Law, the larger the magnitude of the charges on each particle, the stronger the attraction will be.

Example,  $Mg^{2+}$  and  $O^{2-}$  will have a stronger attraction than  $Na^+$  and  $Cl^-$ , because of the larger charges. Also, the closer together the charges are, the stronger the attraction. Therefore, smaller ions also form stronger ionic bonds.

### **Lattice Energy**

Lattice Energy is used to explain the stability of ionic solids. Lattice Energy is a type of potential energy that may be defined in two ways.

The lattice energy is the energy required to break apart an ionic solid and convert its component atoms into gaseous ions and the value for the lattice energy is always be positive and it is endothermic reaction. Lattice energy is the reverse process, which means it is the energy released when gaseous ions bind to form an ionic solid, this process will always be exothermic, and thus the value for lattice energy will be negative. Its values are usually expressed with the units kJ/mol.

The lattice energy is not exactly the same as that predicted by Coulomb's Law, but the same general principles of electrostatic attraction apply. In an ionic compound, the value of the lattice energy corresponds to the strength of the ionic bonding.

### Calculating (Ionic) Lattice Energies

The lattice energy of nearly any ionic solid can be calculated rather accurately using a modified form of Coulomb's law:  $U = -K (Q_1 Q_2)/r_0$

Because lattice energy is inversely related to the internuclear distance, it is also inversely proportional to the size of the ions. The lattice energy decreases for the series  $LiX$ ,  $NaX$ , and  $KX$  as the radius of  $X^-$  increases. Because  $r_0$  is the sum of the ionic radii of the cation and the anion ( $r_0 = r^+ + r^-$ ),  $r_0$  increases as the cation becomes larger in the

series, so the magnitude of  $U$  decreases. A similar effect is seen when the anion becomes larger in a series of compounds with the same cation.

Because the ionic radii of the cations decrease in the order  $K^+ > Na^+ > Li^+$  for a given halide ion, the lattice energy decreases smoothly from  $Li^+$  to  $K^+$ . Conversely, for a given alkali metal ion, the fluoride salt always has the highest lattice energy and the iodide salt the lowest.

### Lattice Energy also depends on Crystal Structure

let us consider the ionic solids as a collection of positive and negative ions. In this simple view, appropriate number of cations and anions come together to form a solid. The positive ions experience both attraction and repulsion from ions of opposite charge and ions of the same charge.

As an example, let us consider the the NaCl crystal.

In the following discussion, assume  $r$  be the distance between  $Na^+$  and  $Cl^-$  ions. The nearest neighbors of  $Na^+$  are 6  $Cl^-$  ions at a distance  $1r$ , 12  $Na^+$  ions at a distance  $2r$ , 8  $Cl^-$  at  $3r$ , 6  $Na^+$  at  $4r$ , 24  $Na^+$  at  $5r$ , and so on. Thus, the electrostatic potential of a single ion in a crystal by approximating the ions by point charges of the surrounding ions:

$$E_{ion-lattice} = Z^2 e^2 M / 4\pi\epsilon_0 r$$

The Madelung constant  $M$  is a geometrical factor that depends on the arrangement of ions in the solid. For example,  $M$  for NaCl is a poorly converging series of interaction energies:

$$M = 6/1 - 12/2 + 8/3 - 6/4 + 24/5 \dots\dots\dots$$

with

$Z$  is the number of charges of the ions, (e.g. 1 for NaCl),

$e$  is the charge of an electron ( $1.6022 \times 10^{-19} C$ ),

$4\pi\epsilon_0$  is  $1.11265 \times 10^{-10} C^2 / (J m)$

### ***Madelung Constants.***

| Compound          | Crystal Lattice | M       | A:C   | Type      |
|-------------------|-----------------|---------|-------|-----------|
| NaCl              | NaCl            | 1.74756 | 6 : 6 | Rock salt |
| CsCl              | CsCl            | 1.76267 | 6 : 6 | CsCl type |
| CaF <sub>2</sub>  | Cubic           | 2.51939 | 8 : 4 | Fluorite  |
| CdCl <sub>2</sub> | Hexagonal       | 2.244   |       |           |

|                                |              |         |       |          |
|--------------------------------|--------------|---------|-------|----------|
| MgF <sub>2</sub>               | Tetragonal   | 2.381   |       |          |
| ZnS (wurtzite)                 | Hexagonal    | 1.64132 |       |          |
| TiO (rutile)                   | Tetragonal   | 2.408   | 6 : 3 | Rutile   |
| SiO <sub>2</sub>               | Hexagonal    | 2.2197  |       |          |
| Al <sub>2</sub> O <sub>3</sub> | Rhombohedral | 4.1719  | 6 : 4 | Corundum |

*A is the number of anions coordinated to cation and C is the numbers of cations coordinated to anion.*

There are other factors to consider for the evaluation of lattice energy and the treatment by Max Born and Alfred Landé led to the formula for the evaluation of lattice energy for a mole of crystalline solid. The Born–Landé equation (Equation ) is a means of calculating the lattice energy of a crystalline ionic compound and derived from the electrostatic potential of the ionic lattice and a repulsive potential energy term

$$U = \frac{N_A M z^+ z^- e^2}{4\pi\epsilon_0 r_0} (1 - 1/n)$$

where

- ▲  $N_A$  is Avogadro constant
- ▲  $M$  is the Madelung constant for the lattice
- ▲  $Z^+$  is the charge number of cation
- ▲  $Z^-$  is the charge number of anion
- ▲  $e$  is elementary charge ( $1.6022 \times 10^{-19} \text{C}$ )
- ▲  $\epsilon_0$  is the permittivity of free space ( $8.854 \times 10^{-12} \text{C}^2/\text{m}$ )
- ▲  $r_0$  is the distance to closest ion
- ▲  $n$  is the Born exponent that is typically between 5 and 12 and is determined experimentally.  $n$  is a number related to the electronic configurations of the ions involved

**n values for select solids**

| Atom/Molecule | He | Ne | Ar | Kr | Xe | LiF | LiCl | LiBr | NaCl | NaBr |
|---------------|----|----|----|----|----|-----|------|------|------|------|
| n             | 5  | 7  | 9  | 10 | 12 | 5.9 | 8.0  | 8.7  | 9.1  | 9.5  |

Problem: Estimate the lattice energy for NaCl

## The Relationship between Lattice Energies and Physical Properties

The magnitude of the forces that hold an ionic substance together has a dramatic effect on many of its properties.

- ▲ The melting point, for example, is the temperature at which the individual ions have enough kinetic energy to overcome the attractive forces that hold them in place. At the melting point, the ions can move freely, and the substance becomes a liquid. Thus melting points vary with lattice energies for ionic substances that have similar structures. The melting points of the sodium halides for example, decrease smoothly from NaF to NaI, following the same trend as seen for their lattice energies. Similarly, the melting point of MgO is 2825°C, compared with 996°C for NaF, reflecting the higher lattice energies associated with higher charges on the ions. In fact, because of its high melting point, MgO is used as an electrical insulator in heating elements for electric stoves.
- ▲ The hardness of ionic materials (resistance to scratching or abrasion) is also related to their lattice energies. Hardness is directly related to how tightly the ions are held together electrostatically, is also reflected in the lattice energy. Example, MgO is harder than NaF, which is consistent with its higher lattice energy.
- ▲ In addition to determining melting point and hardness, lattice energies affect the solubilities of ionic substances in water. In general, the higher the lattice energy, the less soluble a compound is in water. For example, the solubility of NaF in water at 25°C is 4.13 g/100 mL, but under the same conditions, the solubility of MgO is only 0.65 mg/100 mL, meaning that it is essentially insoluble.

*High lattice energies lead to hard, insoluble compounds with high melting points.*

### **THE BORN-HABER CYCLE**

In principle, lattice energies could be measured by combining gaseous cations and anions to form an ionic solid and then measuring the heat evolved thereby the quantities of gaseous ions have never been obtained. Instead, lattice energies are found using the experimentally determined enthalpy changes for other chemical processes, Hess's law, and a thermochemical cycle called the Born-Haber cycle. Developed by Max Born and Fritz



Haber in 1919, the Born–Haber cycle describes a process in which an ionic solid is conceptually formed from its component elements in a stepwise manner.

### Born–Haber cycle of CsF(s)

Let's use the Born–Haber cycle to determine the lattice energy of CsF(s). CsF is a nearly ideal ionic compound because Cs is the least electronegative element that is not radioactive and F is the most electronegative element. To construct a thermochemical cycle for the formation of CsF, enthalpy of formation,  $\Delta H_f^\circ$  has to know, which is defined by the following chemical reaction: Because enthalpy is a state function, the overall for a series of reactions is the sum of the values of for the individual reactions.

The Born-Haber cycle is an application of Hess's law that breaks down the formation of an ionic solid into a series of individual steps:

- ▲  $\Delta H_f^\circ$  the standard enthalpy of formation of the compound
- ▲  $IE$ , the ionization energy of the metal
- ▲  $EA$ , the electron affinity of the nonmetal
- ▲  $\Delta H_s^\circ$  the enthalpy of sublimation of the metal
- ▲  $D$ , the bond dissociation energy of the nonmetal
- ▲  $\Delta H_{\text{lattice}}$ , the lattice energy of the compound

The figure below diagrams the Born-Haber cycle for the formation of solid cesium fluoride.

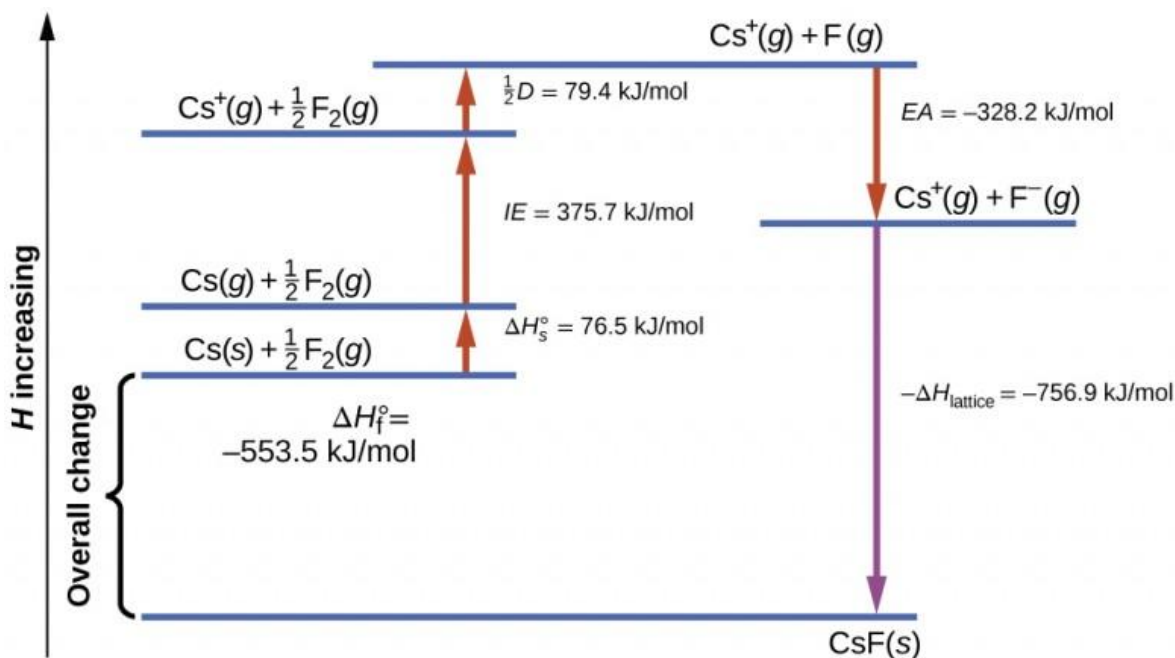

The elements in their most common states,  $\text{Cs}(s)$  and  $\text{F}_2(g)$ . The  $\Delta H^\circ_s$  represents the conversion of solid cesium into a gas, and then the ionization energy converts the gaseous cesium atoms into cations. In the next step, the energy required to break the F–F bond to produce fluorine atoms has to be accounted. Converting one mole of fluorine atoms into fluoride ions is an exothermic process, so this step gives off energy (the electron affinity). Now one mole of Cs cations and one mole of F anions combine to produce solid CsF.

The enthalpy change in this step is the negative of the lattice energy, so it is also an exothermic quantity. The total energy involved in this conversion is equal to the experimentally determined enthalpy of formation  $\Delta H^\circ_f$ , of the compound from its elements. In this case, the overall change is exothermic. Hess's law can also be used to show the relationship between the enthalpies of the individual steps and the enthalpy of formation. The table below shows this for fluoride, CsF.

|   |   |
|---|---|
| Enthalpy of sublimation of $\text{Cs}(s)$         | $\text{Cs}(s) \rightarrow \text{Cs}(g)$   |
| One-half of the bond energy of $\text{F}_2$       | $\frac{1}{2} \text{F}_2(g) \rightarrow \text{F}(g)$   |
| Ionization energy of $\text{Cs}(g)$               | $\text{Cs}(g) \rightarrow \text{Cs}^+(g) + e^-$   |
| Negative of the electron affinity of F            | $\text{F}(g) + e^- \rightarrow \text{F}^-(g)$   |
| Negative of the lattice energy of $\text{CsF}(s)$ | $\text{Cs}^+(g) + \text{F}^-(g) \rightarrow \text{CsF}(s)$                                    |
| Enthalpy of formation of $\text{CsF}(s)$ ,        | $\Delta H = \Delta H^\circ_f = \Delta H^\circ_s + \frac{1}{2} D + \text{IE} + (-\text{EA}) +$ |
| add steps 1–5                                     | $\text{Cs}(s) + \frac{1}{2} \text{F}_2(g) \rightarrow \text{CsF}(s)$                          |

Thus, the lattice energy can be calculated from other values. For cesium fluoride, using this data, the lattice energy is:

$$\Delta H_{\text{lattice}} = 9553.5 + 76.5 + 79.4 + 375.7 + 328.2 \text{ kJ/mol} = 1413.3 \text{ kJ/mol}$$

The Born-Haber cycle may also be used to calculate any one of the other quantities in the equation for lattice energy, provided that the remainder is known. For example, if the relevant enthalpy of sublimation  $\Delta H^\circ_s$ , ionization energy (IE), bond dissociation enthalpy (D), lattice energy  $\Delta H_{\text{lattice}}$ , and standard enthalpy of formation  $\Delta H^\circ_f$  are known, the Born-Haber cycle can be used to determine the electron affinity of an atom.

Lattice energies calculated for ionic compounds are typically much higher than bond dissociation energies measured for covalent bonds. Whereas lattice energies typically fall in the range of 600–4000 kJ/mol (some even higher), covalent bond dissociation energies are typically between 150–400 kJ/mol for single bonds.

## Born-Haber Cycle For NaCl

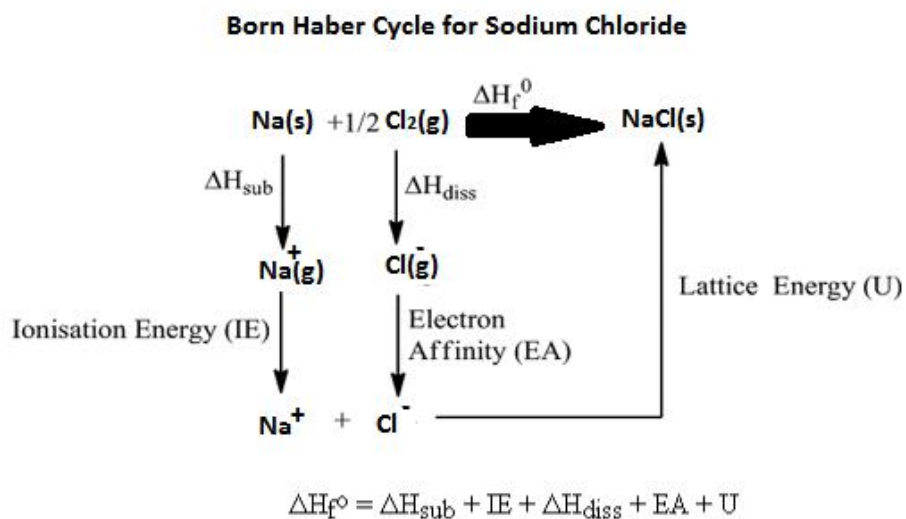

### Step 1

Determine the energy of the metal and nonmetal in their elemental forms. (Elements in their natural state have an energy level of zero.) Subtract from this the heat of formation of the ionic solid that would be formed from combining these elements in the appropriate ration. This is the energy of the ionic solid, and will be used at the end of the process to determine the lattice energy.

### Step 2

The Born-Haber Cycle requires that the elements involved in the reaction are in their gaseous forms. Add the changes in enthalpy to turn one of the elements into its gaseous state, and then do the same for the other element.

### Step 3

Metals exist in nature as single atoms and thus no dissociation energy needs to be added for this element. However, many nonmetals will exist as polyatomic species. For example, Cl exists as Cl<sub>2</sub> in its elemental state. The energy required to change Cl<sub>2</sub> into 2Cl atoms must be added to the value obtained in Step 2.

### Step 4

Both the metal and nonmetal now need to be changed into their ionic forms, as they would exist in the ionic solid. To do this, the ionization energy of the metal will be added to the value from Step 3. Next, the electron affinity of the nonmetal will be subtracted from the

previous value. It is subtracted because it is a release of energy associated with the addition of an electron.

\*This is a common error due to confusion caused by the definition of electron affinity, so be careful when doing this calculation.

### Step 5

Now the metal and nonmetal will be combined to form the ionic solid. This will cause a release of energy, which is called the lattice energy. The value for the lattice energy is the difference between the value from Step 1 and the value from Step 4.

**The Born-Haber Cycle can be reduced to a single equation:**

Heat of formation = Heat of atomization + Dissociation energy + (sum of Ionization energies) + (sum of Electron affinities) + Lattice energy

\*Note: In this general equation, the electron affinity is added. However, when plugging in a value, determine whether energy is released (exothermic reaction) or absorbed (endothermic reaction) for each electron affinity. If energy is released, put a negative sign in front of the value; if energy is absorbed, the value should be positive.

Rearrangement to solve for lattice energy gives the equation:

Lattice energy = Heat of formation - Heat of atomization - Dissociation energy - (sum of Ionization energies) - (sum of Electron Affinities)

## **POLARIZATION OF ION**

During the formation of an ionic compound or ionic molecules, two oppositely charged ions (cations and anions) must come closer to each other. During this process, the cation attracts the electron charge cloud of the outermost shell of the anion toward itself, therefore, the symmetrical shape of the anion gets distorted or deformed, or polarized.

The phenomenon of the distortion of the symmetrical shape of the electron cloud of anion in the nearby cation is called polarization of anion.

Example: In LiI, the electron cloud of I<sup>-</sup> anion is distorted by cation Li<sup>+</sup>, which is shown below

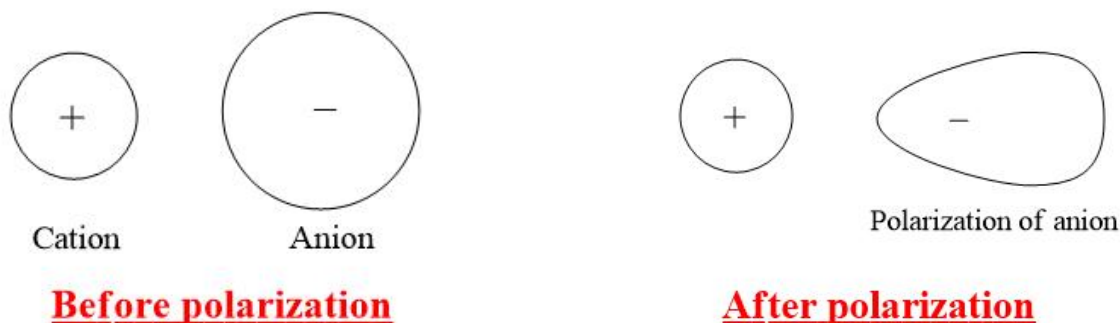

There is also the chance of the polarization of cation by anion but due to the smaller size of the cation, its electrons cloud is strongly held to the nucleus, and therefore, the shape of the cloud is not distorted to an appreciable extent. Hence, the polarization of cation by an anion is not generally considered.

### **Polarizing power**

The ability of a cation to polarize an anion is called polarizing power or polarizing ability.

#### Factors affecting polarizing power

- ✓ Magnitude of positive charge on the cation
  - ✓ Size of cation
  - ✓ Electronic configuration of the cation
- ▲ Magnitude of positive charge on the cation

The greater the charge on the cation, the more strongly it attracts the outermost shell electron cloud of an anion toward itself and polarizes the given anion easily. Therefore, the polarizing power of cation is directly proportional to the magnitude of the positive charge on it.

Example:  $\text{Na}^+ < \text{Mg}^{++} < \text{Al}^{+++}$

if the same element has a different positive charge, the higher positive charge has greater power of polarization. For example  $\text{Sn}^{4+} > \text{Sn}^{2+}$

- ▲ Size of cation

The smaller the size of the cation, the more strongly it attracts the outermost shell electron cloud of an anion towards itself, and hence, the greater is its polarizing ability. In other words, with the decreasing size of the cation, the polarizing power of the cation increases. Thus, the Polarizing power of the cation is inversely proportional to the size of the cation. Example:  $\text{Li}^+ > \text{Na}^+ > \text{K}^+ > \text{Rb}^+$

▲ Electronic configuration of the cation

What if two cations have the same positive charge and almost the same size?

In such a case, the electronic configuration of cations determines their polarizing ability. A cation having  $ns^2p^6d^{1-10}$  electronic configuration will polarize the given anion to a greater extent than the cation having  $ns^2p^6$  electronic configuration. This can be explained on the basis of the shielding effect of d-electrons. The d-electrons shield the nucleus poorly as compared to the s and p-electrons. Thus, cations having d-electrons have poorer shielding of the nucleus than s- and p-electrons.

**Polarizability of anion**

The tendency of an anion to get polarized by a cation is called its polarizability.

Factors affecting polarizability

- ✓ Magnitude of the negative charges on the anion
- ✓ Size of the anion

▲ Magnitude of negative charges on anion

The higher the negative charge on the anion, the more easily its outermost electron cloud is attracted by cations and hence anion is polarized to a greater extent. Thus, the polarisability of an anion is directly proportional to the magnitude of the negative charges on it.

For example:  $C^{4-} > N^{3-} > O^{2-} > F^-$

▲ Size of the anion

The larger the size of the anion, the more easily its outermost shell electron cloud is attracted by the cation towards itself, and hence, the greater the polarisability of an anion. Thus, the polarisability of an anion is directly proportional to the size of the anion.

Example:  $F^- < Cl^- < Br^- < I^-$

## FAJAN'S RULES

The chemical bonds are divided broadly into ionic and covalent types, however, in reality, most of the bonds are neither purely ionic nor purely covalent.

The ionic bond refers to the complete transfer of electrons from one atom to the other, whereas the pure covalent bond involves equal sharing of electrons. Nevertheless, the nature of chemical bonds in most of the compounds is in between above said two extremes.

In general, it is expected that the ionic compounds are soluble in polar solvents like water and show high melting and boiling points as well as exhibit electrical conductivity in the liquid state. As a rule, these compounds should be sparingly soluble in nonpolar solvents like benzene, carbon tetrachloride, etc. However, it is observed that few of the ionic compounds are also fairly soluble in them and also exhibit somewhat less than anticipated melting points and electrical conductivity in the molten state.

But some of the covalent compounds are soluble in water and exhibit electrical conductivity, though not very much, in the molten state.

### Consequences of polarization

Due to polarization of anion and the increase in covalent nature, the ionic compounds exhibit abnormal behavior as mentioned below.

i. Solubility in non-polar solvents:

It is observed that the ionic compounds with covalent nature are appreciably soluble in the non-polar solvents with low dielectric constants.

ii. Low melting points:

The melting points of ionic compounds with covalent character are less than anticipated.

iii. Stability:

Due to polarization, the anions may undergo easy oxidation when exposed to certain conditions. The polyatomic oxyanions like carbonates, sulfates, etc. are distorted very easily in presence of cations with greater polarizing power and therefore are decomposed very easily upon heating.

### Fajan's rules of polarization

- i. The smaller the cation or the larger the anion, the greater is the covalent nature of an ionic compound.

- ii. The greater the charge on either cation or anion, the greater is the covalent nature of an ionic compound.
- iii. The ionic compound containing cations with octet configuration have greater ionic nature while those containing cations with pseudo-octet configuration have appreciable covalent character.

#### Applications of fajans' rule-1 with examples

##### *Covalent nature of alkali metal halides:*

When the alkali metal ion is changed while the halide is fixed, the trend in covalent nature depends on the size of cations.

- ▲ The size of cations increases from top to bottom in a given group of periodic table. Therefore the cation size of alkali metals also increases as shown below.  $\text{Li}^+ < \text{Na}^+ < \text{K}^+ < \text{Rb}^+ < \text{Cs}^+$
- ▲ Therefore the covalent nature of alkali metal halides containing the same halide ion decreases from Lithium halide to Cesium halide according to Fajan's rule-1.
- ▲ For example, the decreasing order of covalent nature of alkali metal chlorides is:  $\text{LiCl} > \text{NaCl} > \text{KCl} > \text{RbCl} > \text{CsCl}$

The solubility of these compounds in non polar solvents with low dielectric constant also decreases in the same order. While the melting points follow the reverse order due to the decrease in covalent character (or increase in ionic nature).

When the alkali metal ion is fixed while the halide is changed, the trend in covalent nature depends on the size of anion.

- ▲ For example the order of covalent character for Lithium halides with different halide ions is as shown below.  $\text{LiF} < \text{LiCl} < \text{LiBr} < \text{LiI}$
- ▲ In the above case, the size of anion increases from fluoride to iodide ion and hence the covalent nature increases.
- ▲ The stability of these compounds, however, decreases from LiF to LiI due to increase in polarization of anion.
- ▲ Lithium iodide becomes yellow when exposed to air due to oxidation of Iodide to Iodine. It is due to strong polarization of larger Iodide anion in presence of smaller lithium ion.



### Applications of fajans' rule-2

- ⤴ The covalent nature of chlorides of Na, Mg & Al is in the following order.
- ⤴  $\text{NaCl} < \text{MgCl}_2 < \text{AlCl}_3$
- ⤴ It is due to increase in the positive charge on cations i.e.  $\text{Na}^+ < \text{Mg}^{2+} < \text{Al}^{3+}$ .

### Applications of fajans' rule-3

- ⤴ When the cations have octet configuration or inert gas configuration ( $ns^2np^6$ ) in their outer shells, the effective nuclear charge properly shielded by the inner s and p electrons. Hence their polarizing power is less than expected. Therefore the ionic compound with these cations have less covalent character.
- ⤴ Whereas, the nuclear attraction is not properly shielded when there are electrons in the d-sub-level. Therefore the cations with pseudo-octet configuration i.e.  $ns^2np^6nd^{10}$  possess high polarizing power.
- ⤴ Therefore the main group metal compounds are more ionic while the transition metal compounds are more covalent.
- ⤴ For example,  $\text{CaCl}_2$  is more ionic due to the inert gas configuration ( $3s^23p^6$ ) in the  $\text{Ca}^{2+}$  ion. While the  $\text{ZnCl}_2$  is more covalent due to pseudo-inert gas configuration in the  $\text{Zn}^{2+}$  ion ( $3s^23p^63d^{10}$ ).

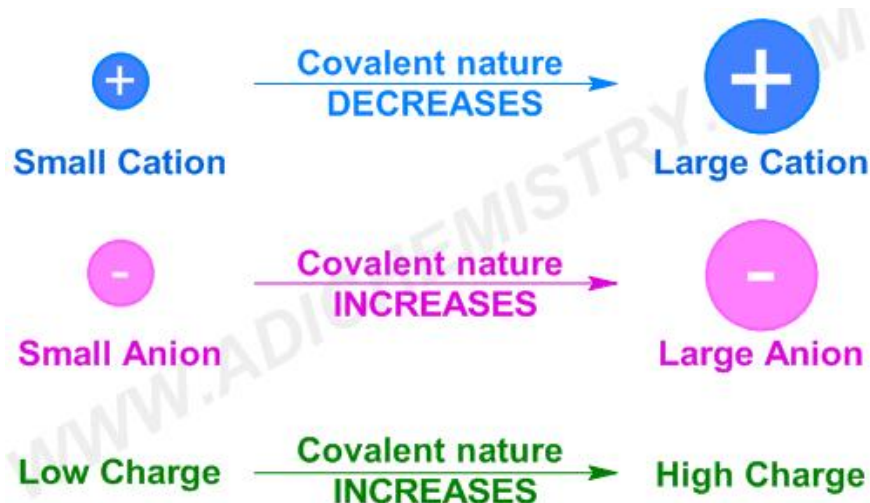

## QUANTUM NUMBERS

These are certain numbers used to explain the size, shape and orientation of orbitals. Or, Quantum numbers are the address of an electron. There are four quantum numbers which describe the electron in an atom. They are Principal Quantum number ( $n$ ), Azimuthal Quantum number ( $l$ ), Magnetic Quantum number ( $m$  or  $m_l$ ) and Spin Quantum number ( $s$ )

### Principal Quantum Number ( $n$ )

- The following informations are obtained from  $n$ .
- It gives the size the orbit.
- It gives the energy of electron in an orbit.
- It gives the shell in which the electron is found.
- It also gives the average distance between the electron and the nucleus. As the value of  $n$  increases, the distance between the electron and the nucleus also increases.

The possible values of  $n$  are 1, 2, 3, 4, 5 etc.

If  $n = 1$  the electron is in K shell

$n = 2$  the electron is in L shell

$n = 3$  the electron is in M shell and so on.

### Azimuthal Quantum Number [orbital angular momentum Quantum number] ( $l$ )

The following informations are obtained from  $l$ .

It gives the shape of the orbital.

It gives the sub shell or sub level in which the electron is located.

It also gives the orbital angular momentum of the electron.

For a given value of  $n$ ,  $l$  can have  $n$  values ranging from 0 to  $n - 1$ . That is, for a given value of  $n$ , the possible value of  $l$  are :  $l = 0, 1, 2, \dots, (n-1)$ .

For example, when  $n = 1$ , the possible value of  $l$  is only 0.

For  $n = 2$ , the possible value of  $l$  can be 0 and 1.

For  $n = 3$ , the possible value  $l$  values are 0,1 and 2.

$l = 0$  represents s orbital,  $l = 1$  represents p orbital,  $l = 2$  represents d orbital and  $l = 3$  represents f orbital

The number of sub shells in a principal shell is equal to the value of  $n$ . For example,

When  $n = 1$ ,  $l = 0$ . i.e. K shell contains only one sub shell - s sub shell

when  $n = 2$ ,  $l = 0$  and 1. i.e. L shell contains two sub shells - s and p sub shells

when  $n = 3$ ,  $l = 0, 1$  and  $2$ . i.e. M shell contains three sub shells – s, p and d sub shells  
when  $n = 4$ ,  $l = 0, 1, 2$  and  $3$ . i.e. N shell contains four sub shells – s, p, d and f sub shells

### Magnetic Quantum Number (m or $m_l$ )

It gives information about the orientation of orbitals in space. For a given 'l' value, there are  $2l+1$  possible values for m and these values are given by :  $m = -l$  to  $0$  to  $+l$

Thus for  $l = 0$ ,  $m_l = 0$  [ $2(0)+1 = 1$ ]. i.e. s sub shell contains only one orbital called s orbital.

For  $l = 1$ ,  $m_l = -1, 0$  and  $+1$  [ $2(1)+1 = 3$ ]. i.e. p subshell contains three orbitals called p orbitals ( $p_x, p_y$  and  $p_z$ ).

For  $l = 2$ ,  $m_l = -2, -1, 0, +1$  and  $+2$ , [ $2(2)+1 = 5$ ]. i.e. d subshell contains five orbitals called d orbitals ( $d_{xy}, d_{xz}, d_{yz}, d_{x^2-y^2}$  and  $d_z^2$ )

For  $l = 3$  and  $m_l = -3, -2, -1, 0, +1, +2$  and  $+3$ . i.e., f subshell contains seven orbitals called f orbitals  $f_x^3, f_y^3, f_z^3, f_{x(y^2-z^2)}, f_{y(z^2-x^2)}, f_{z(x^2-y^2)}$  and  $f_{xyz}$

### Spin Quantum Number (s or $m_s$ )

It is the only experimental Quantum number and it gives the spin orientation of electrons. This spin may be either clockwise or anticlockwise. So the values for s may be  $+\frac{1}{2}$  or  $-\frac{1}{2}$ .  $+\frac{1}{2}$  represents clock-wise spin and  $-\frac{1}{2}$  represents anticlock-wise spin.

## SHAPES OF ORBITALS

### s-orbitals

For s-orbitals,  $l = 0$  and hence  $m_l = 0$ . So there is only one possible orientation for s orbitals. They are spherically symmetrical.

For 1s orbital the probability density is maximum at the nucleus and it decreases with increase in r. But for 2s orbital the probability density first decreases sharply to zero and again starts increasing. After reaching a small maximum it decreases again and approaches zero as the value of r increases. The region where the probability density ( $\psi^2$ ) reduces to zero is called nodal surface or node. For 1s orbital, there is no node, for 2s orbital there is only one node, for 3s orbital there are 2 nodes and so on. In general, for an ns-orbital there are  $(n - 1)$  nodes. All the s-orbitals are spherically symmetrical and their size increases with in n. The boundary surface diagrams for 1s, 2s and 3s orbitals are as follows:

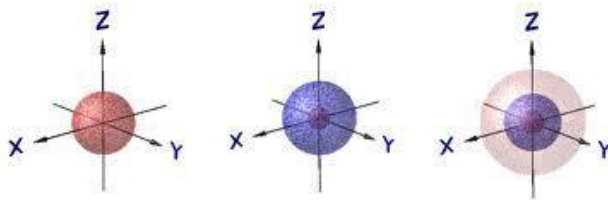

### p-orbitals

For p-orbitals,  $l = 1$  and  $m_l = -1, 0, +1$ . i.e., there are three possible orientations for p orbitals. So there are 3 types of p-orbitals ( $p_x$ ,  $p_y$  and  $p_z$ ). Each p orbital consists of two lobes. The probability density function is zero on the plane where the two lobes touch each other. The size, shape and energy of the three orbitals are identical. They differ only in the orientation of the lobes. For  $p_x$  orbital, the lobes are along the x-axis, for  $p_y$ , they are along the y-axis and for  $p_z$ , they are along the z-axis. All the p-orbitals have dumb-bell shape. The number of radial nodes for p-orbitals are given by  $(n - 2)$ , that is number of radial node is 1 for 3p orbital, two for 4p orbital and so on. Besides the radial nodes, the probability density functions for the np orbitals are zero at the plane, passing through the nucleus (origin). For example, in the case of  $p_z$  orbital, xy plane is a nodal plane. These are called angular nodes and number of angular nodes is given by 'l'.

Number of radial nodes =  $n - l - 1$

Number of angular nodes =  $l$

Total number of nodes =  $n - 1$

The boundary surface diagrams for three 2p orbitals are as follows:

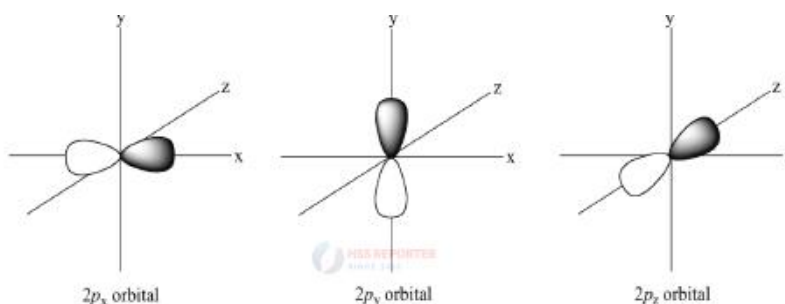

### d-orbitals

For d-orbitals,  $l = 2$  and  $m_l = -2, -1, 0, +1$  and  $+2$ . i.e., there are five possible orientations for d orbitals. So there are 5 types of d-orbitals. They are  $d_{xy}$ ,  $d_{xz}$ ,  $d_{yz}$ ,  $d_{x^2 - y^2}$  and  $d_{z^2}$ . The shapes of the first four d-orbitals are double dumb-bell and that of the fifth one,  $d_{z^2}$ , is dumb-bell having a circular collar in the xy-plane. The five d-orbitals have equivalent

energies. For d-orbitals the number of radial nodes is 2 and the total number of nodes is  $n-2$ . Boundary surface diagrams for d-orbitals are as follows:

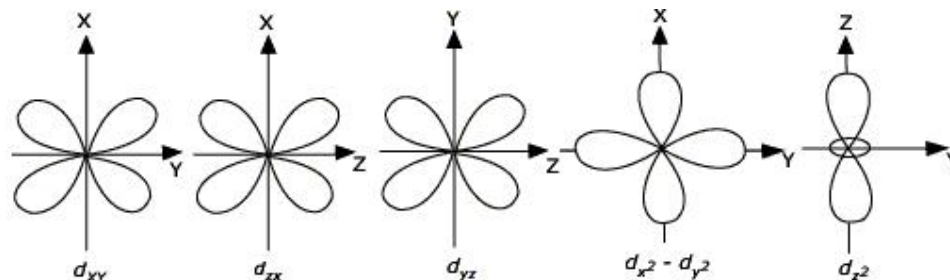

### f-orbitals

For f-orbitals,  $l = 3$  and  $m_l = -3, -2, -1, 0, +1, +2$  and  $+3$ . i.e., there are seven possible orientations for f orbitals. So there are 7 types of f-orbitals. They are  $f_x^3$ ,  $f_y^3$ ,  $f_z^3$ ,  $f_x(y^2-z^2)$ ,  $f_y(z^2-x^2)$ ,  $f_z(x^2-y^2)$  and  $f_{xyz}$ . They have diffused shapes.

## HYBRIDIZATION

Hybridization, is defined as the concept of mixing two atomic orbitals to give rise to a new type of hybridized orbitals having entirely different energy, shapes, etc. The atomic orbitals of the comparable same energy level mainly take part in hybridization i.e., the merging of two 's' orbitals or two 'p' orbitals or the mixing of an 's' orbital with a 'p' orbital, as well as 's' orbital with a 'd' orbital. The new orbitals, thus formed, are known as hybrid orbitals. More significantly, hybrid orbitals are quite useful in explaining atomic bonding properties and molecular geometry. However, both fully-filled and half-filled orbitals can also take part in this process, provided they have equal energy.

### Key Features of Hybridization

- Atomic orbitals with equal energies undergo hybridization.
- The number of hybrid orbitals formed is equal to the number of atomic orbitals mixed.
- It is not necessary that all the half-filled orbitals must participate in hybridization. Even completely filled orbitals with slightly different energies can also participate.
- The shape of the molecule can be predicted if the hybridization of the molecule is known.
- The bigger lobe of the hybrid orbital always has a positive sign, while the smaller lobe on the opposite side has a negative sign.

## Types of Hybridization

### ***sp Hybridization***

- The sp hybridization is also called diagonal hybridization.
- sp hybridization is observed when one s and one p orbital in the same main shell of an atom mix to form two new equivalent orbitals called sp hybridized orbitals
- This type of hybridization involves the mixing of one 's' orbital and one 'p' orbital of equal energy to give a new hybrid orbital known as an sp hybridized orbital.
- It forms linear molecules with an angle of 180°.
- Each sp hybridized orbital has an equal amount of s and p characters – 50% s and 50% p characters.
- All compounds of beryllium, like BeF<sub>2</sub>, BeH<sub>2</sub>, BeCl<sub>2</sub> and carbon-containing triple bond, like C<sub>2</sub>H<sub>2</sub>.

### ***sp<sup>2</sup> Hybridization***

- sp<sup>2</sup> hybridization is also called trigonal hybridization.
- sp<sup>2</sup> hybridization is observed when one s and two p orbitals of the same shell of an atom mix to form 3 equivalent orbitals called sp<sup>2</sup> hybrid orbitals.
- It involves the mixing of one 's' orbital and two 'p' orbitals of equal energy to give a new hybrid orbital known as sp<sup>2</sup>.
- All three hybrid orbitals remain in one plane and make an angle of 120° with one another.
- Each sp<sup>2</sup> hybrid orbitals formed has a 33.33% 's' character and 66.66% 'p' character.
- The molecules in which the central atom is linked to 3 atoms and is sp<sup>2</sup> hybridized have a triangular planar shape.
- All the compounds of Boron, i.e., BF<sub>3</sub> and BH<sub>3</sub> and carbon-carbon double bond, Ethylene (C<sub>2</sub>H<sub>4</sub>)

### ***sp<sup>3</sup> Hybridization***

- sp<sup>3</sup> Hybridization is also called tetrahedral hybridization
- When one 's' orbital and 3 'p' orbitals belonging to the same shell of an atom mix together to form four new equivalent orbitals called sp<sup>3</sup> hybrid orbitals.
- These are directed towards the four corners of a regular tetrahedron and make an angle of 109°28' with one another.

- Each  $sp^3$  hybrid orbital has 25% s character and 75% p character.
- Examples of  $sp^3$  hybridization are ethane ( $C_2H_6$ ) and methane.

### $sp^3d$ Hybridization

- $sp^3d$  hybridization involves the mixing of 1s orbital, 3p orbitals and 1d orbital to form five  $sp^3d$  hybridized orbitals of equal energy. They have trigonal bipyramidal geometry.
- Three hybrid orbitals lie in the horizontal plane inclined at an angle of  $120^\circ$  to each other, known as the equatorial orbitals.
- The remaining two orbitals lie in the vertical plane at  $90^\circ$  plane of the equatorial orbitals, known as axial orbitals.
- Example: Hybridization in phosphorus pentachloride ( $PCl_5$ )

### $sp^3d^2$ Hybridization

- $sp^3d^2$  hybridization has 1s, 3p and 2d orbitals, that undergo intermixing to form six identical  $sp^3d^2$  hybrid orbitals.
- These six orbitals are directed towards the corners of an octahedron.
- They are inclined at an angle of  $90^\circ$  to one another.
- Example:- sulphur hexafluoride

### Sigma and pi bonds

All single bonds are referred to as 'sigma' bonds ( $\sigma$ -bonds). The electron density is concentrated along the bond axis.

A multiple bond is made up of a combination of sigma and pi bonds ( $\pi$ -bonds). The electron density of a  $\pi$ -bond is concentrated above and below a plane containing the bonded atoms and arises from overlap of two p-orbitals pointing in the same direction.

So, a double bond contains  $1\sigma + 1\pi$  bond and a triple bond contains  $1\sigma + 2\pi$  bonds.

e.g.  $CH_4$  and  $C_2H_6$  contain all  $\sigma$ -bonds.

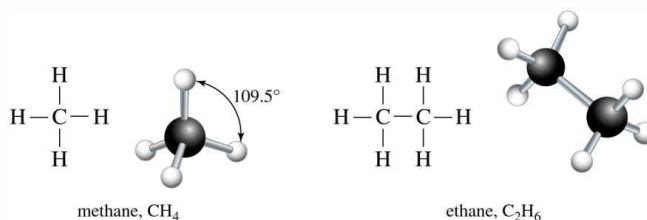

Ethylene,  $C_2H_4$  has the Lewis Structure.



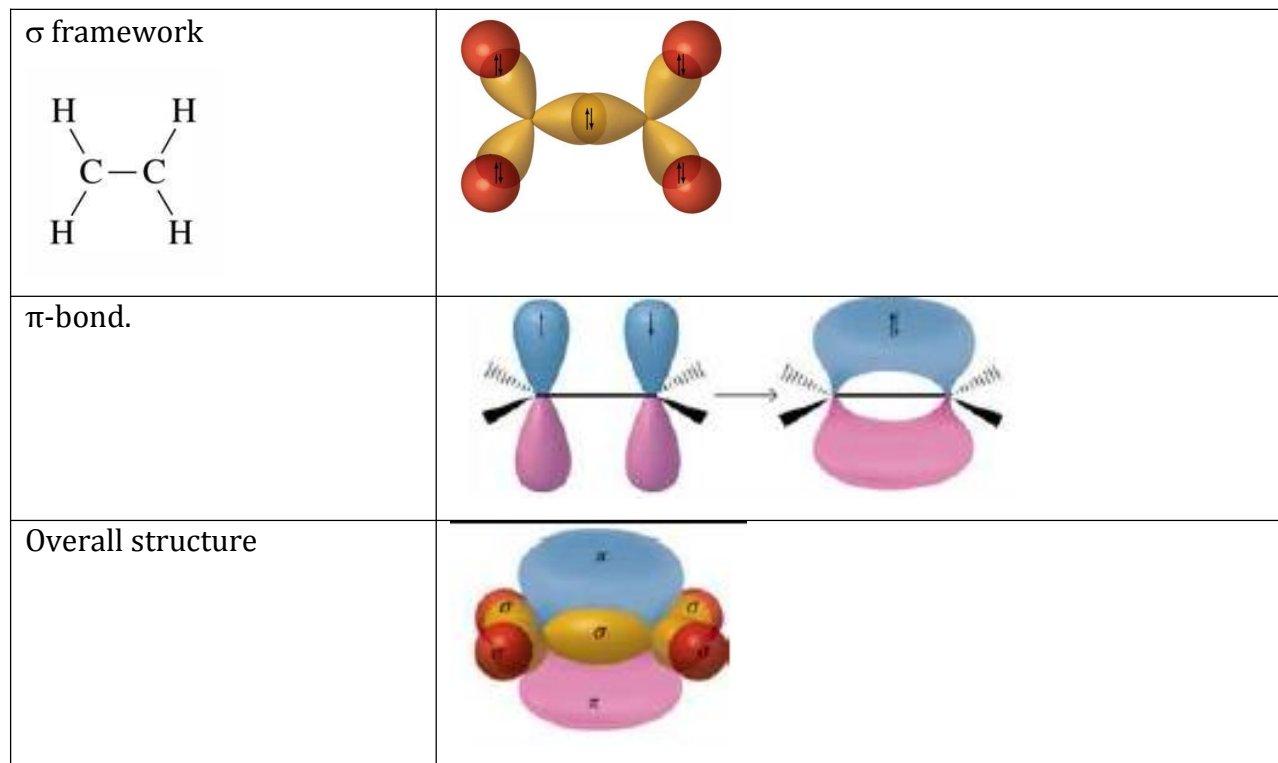













The molecular shape is predicted to be trigonal planar around each carbon atom. This is composed of a  $\sigma$  framework and a  $\pi$ -bond.











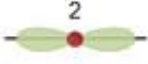

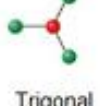
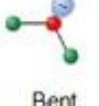
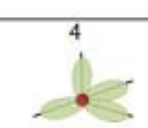
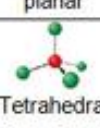
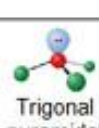

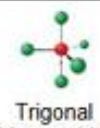
## VSEPR Theory (Valence Shell Electron Pair Repulsion Theory)

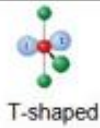
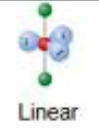
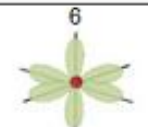
VSEPR theory explains the repulsion between the pairs of valence electrons in all atoms, and the atoms will always tend to arrange themselves in a manner in which this electron pair repulsion is minimized. This arrangement of the atom determines the geometry of the resulting molecule.

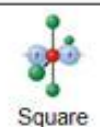
| Total Domains | Generic Formula                | Picture   | Bonded Atoms | Lone Pairs | Molecular Shape    | Electron Geometry  | Example                       | Hybridization                  | Bond Angles |
|---------------|--------------------------------|---|--------------|------------|--------------------|--------------------|-------------------------------|--------------------------------|-------------|
| 1             | AX                             |    | 1            | 0          | Linear             | Linear             | H <sub>2</sub>                | s                              | 180         |
| 2             | AX <sub>2</sub>                |    | 2            | 0          | Linear             | Linear             | CO <sub>2</sub>               | sp                             | 180         |
|               | AXE                            |    | 1            | 1          | Linear             | Linear             | CN <sup>-</sup>               |                                |             |
| 3             | AX <sub>3</sub>                |    | 3            | 0          | Trigonal planar    | Trigonal planar    | AlBr <sub>3</sub>             | sp <sup>2</sup>                | 120         |
|               | AX <sub>2</sub> E              |    | 2            | 1          | Bent               | Trigonal planar    | SnCl <sub>2</sub>             |                                |             |
|               | AXE <sub>2</sub>               |    | 1            | 2          | Linear             | Trigonal planar    | O <sub>2</sub>                |                                |             |
| 4             | AX <sub>4</sub>                |    | 4            | 0          | Tetrahedral        | Tetrahedral        | SiCl <sub>4</sub>             | sp <sup>3</sup>                | 109.5       |
|               | AX <sub>3</sub> E              |   | 3            | 1          | Trigonal pyramid   | Tetrahedral        | PH <sub>3</sub>               |                                |             |
|               | AX <sub>2</sub> E <sub>2</sub> |  | 2            | 2          | Bent               | Tetrahedral        | SeBr <sub>2</sub>             |                                |             |
|               | AXE <sub>3</sub>               |  | 1            | 3          | Linear             | Tetrahedral        | Cl <sub>2</sub>               |                                |             |
| 5             | AX <sub>5</sub>                |  | 5            | 0          | Trigonal bipyramid | Trigonal bipyramid | AsF <sub>5</sub>              | sp <sup>3</sup> d              | 90 and 120  |
|               | AX <sub>4</sub> E              |  | 4            | 1          | See Saw            | Trigonal bipyramid | SeH <sub>4</sub>              |                                |             |
|               | AX <sub>3</sub> E <sub>2</sub> |  | 3            | 2          | T shape            | Trigonal bipyramid | ICl <sub>3</sub>              |                                |             |
|               | AX <sub>2</sub> E <sub>3</sub> |  | 2            | 3          | Linear             | Trigonal bipyramid | BrF <sub>2</sub> <sup>-</sup> |                                |             |
| 6             | AX <sub>6</sub>                |  | 6            | 0          | Octahedral         | Octahedral         | SeCl <sub>6</sub>             | sp <sup>3</sup> d <sup>2</sup> | 90          |
|               | AX <sub>5</sub> E              |  | 5            | 1          | Square pyramid     | Octahedral         | IF <sub>5</sub>               |                                |             |
|               | AX <sub>4</sub> E <sub>2</sub> |  | 4            | 2          | Square planar      | Octahedral         | XeF <sub>4</sub>              |                                |             |

| Number of Electron Dense Areas   | Electron-Pair Geometry | Molecular Geometry  |   |   |   |   |
|--|------------------------|---|---|---|---|---|
|  |                        | No Lone Pairs   | 1 lone Pair   | 2 lone Pairs  | 3 lone Pairs  | 4 lone Pairs  |
| 2<br> | Linear                 | <br>Linear               |   |   |   |   |
| 3<br> | Trigonal planar        | <br>Trigonal planar      | <br>Bent               |   |   |   |
| 4<br> | Tetrahedral            | <br>Tetrahedral          | <br>Trigonal pyramidal | <br>Bent          |   |   |
| 5<br> | Trigonal bipyramidal   | <br>Trigonal bipyramidal | <br>Sawhorse           | <br>T-shaped      | <br>Linear   |   |
| 6<br> | Octahedral             | <br>Octahedral           | <br>Square pyramidal   | <br>Square planar | <br>T-shaped | <br>Linear |

### Postulates of VSEPR Theory

- i. In polyatomic molecules (i.e., molecules made up of three or more atoms), one of the constituent atoms is identified as the central atom to which all other atoms belonging to the molecule are linked.
- ii. The total number of valence shell electron decides the shape of the molecule.
- iii. The electron pairs have a tendency to orient themselves in a way that minimises the electron-electron repulsion between them and maximises the distance between them.
- iv. If the central atom of the molecule be surrounded by *bond pairs of electrons*, then the *asymmetrically shaped* molecule can be expected and the central atom of the molecule be surrounded by both *lone pairs and bond pairs of electrons*, the molecule would tend to have a *distorted shape*.
- v. The strength of the repulsion is strongest in two lone pairs and weakest in two bond pairs.
- vi. If electron pairs around the central atom are closer to each other, they will repel each other. This results in an increase in the energy of the molecules.

- vii. If the electron pairs lie far from each other, the repulsions between them will be less, and eventually, the energy of the molecule will be low.

#### Limitations of VSEPR Theory

- ⤴ This theory fails to explain isoelectronic species (i.e., elements having the same number of electrons). The species may vary in shape, despite having the same number of electrons.
- ⤴ Another limitation of the VSEPR theory is that it predicts that halides of group 2 elements will have a linear structure, whereas their actual structure is a bent one.

#### Predicting the Shapes of Molecules

- ⤴ The least electronegative atom must be selected as the central atom
- ⤴ The total number of electrons belonging to the outermost shell of the central atom (x) must be counted.
- ⤴ The total number of electrons belonging to other atoms and used in bonds with the central atom (y) must be counted.
- ⤴ These two values(x+y) must be added in order to obtain the valence shell electron pair number or the VSEP number.

The VSEP number describes the shape of the molecule, as described as provided below.

| VSEP Number | Shape of the Molecule  |
|-------------|------------------------|
| 2           | Linear                 |
| 3           | Trigonal Planar        |
| 4           | Tetrahedral            |
| 5           | Trigonal Bipyramidal   |
| 6           | Octahedral             |
| 7           | Pentagonal Bipyramidal |

#### *Linear Shape of Molecule*

- In this type of molecule, there would be two places in the valence shell of the central atom.
- They are arranged in such a manner that repulsion between the electrons can be minimised -pointing in the opposite direction. Example:  $\text{BeF}_2$

### *Trigonal Planar Shape of Molecule*

- In this type of molecule, there would be three molecules attached to a central atom.
- They are arranged in such a manner that repulsion between the electrons can be minimised -toward the corners of an equilateral triangle. Example:  $\text{BF}_3$

### *Tetrahedral Shape of Molecule*

- For two-dimensional molecules, atoms lies in the same plane get a square planar geometry in which the bond angle between H-C-H is  $90^\circ$ .
- For a 3D molecule, atoms arrange in tetrahedral shape in which the bond angle between H-C-H is  $109^\circ 28'$  (toward the corners of an equilateral triangle)  $\text{CH}_4$

### *Trigonal Bipyramid Shape of Molecule*

- Here, repulsion can be minimised by the even distribution of electrons towards the corner of a trigonal pyramid. In a trigonal bipyramid, three positions lie along the equator of the molecule. The two positions lie along an axis perpendicular to the equatorial plane. Example- $\text{PF}_5$

### *Octahedral Shape of Molecule*

- Here, repulsion can be minimised by the even distribution of electrons towards the six corners of a regular octahedron where four positions lie along the equator of the molecule. The two positions lie along an axis perpendicular to the equatorial plane.
- There are six hybrid orbitals formed (One 3s-orbital, three 3p-orbitals and two 3d-orbital) Example:  $\text{SF}_6$

### *Pentagonal bipyramidal Shape of Molecule*

- Fluorine atoms are bonded to the central iodine atom in a through equatorial bonds in the pentagonal ring and 2 fluorine atoms are bonded to the central iodine atom through axial bond
- The equatorial bonds are at  $72^\circ$  of an angle to each other.
- It has seven bond pairs and zero lone pairs of electrons. The central iodine atom undergoes  $\text{sp}^3\text{d}^3$  hybridisation which results in pentagonal bipyramidal geometry. Example:  $\text{IF}_7$

## How Can the VSEPR Theory Be Used to Predict the Shapes of Molecules?

The strength of the repulsion between a lone pair and a bond pair of electrons lies in between the repulsion between two lone pairs and between two bond pairs. The order of repulsion between electron pairs is as follows:

Lone Pair- lone pair > Lone Pair- bond- pair > Bond Pair- bond pair

- i. Total number of electron pairs around the central atom =  $\frac{1}{2}$  (Number of valence electrons of central atom + Number of atoms linked to central atom by single bonds)
  - ▲ For negative ions, add the number of electrons equal to the units of negative charge on the ions to the valence electrons of the central atom.
  - ▲ For positive ions, subtract the number of electrons equal to the units of positive charge on the ion from the valence electrons of the central atom.
- ii. The number of bond pairs = the total number of atoms linked to the central atom by single bonds.
- iii. Number of lone pairs = The total number of electrons – No. of shared pair

The electron pairs around the central atom repel each another and move so far apart from each another that there are no greater repulsions between them. This results in the molecule having minimum energy and maximum stability.

- The shape of a molecule with only two atoms is always linear.
- For molecules with three or more atoms, one of the atoms is called the central atom and other atoms are attached to the central atom.
- If the central atom is linked to similar atoms and is surrounded by bond pairs of electrons only, the repulsions between them are similar. As a result, the shape of the molecule is symmetrical, and the molecule is said to have regular geometry.
- If the central atom is linked to different atoms or is surrounded by bond pair, as well as a lone pair of electrons, the repulsion between them is similar. As a result, the shape of the molecule has an irregular or distorted geometry.
- The exact shape of the molecule depends upon the total number of electron pairs present around the central atom.

## PARTIAL IONIC CHARACTER OF COVALENT BOND

A bond is formed when two atoms having similar or almost similar electronegativities share an equal number of electrons. This is the ideal situation for the formation of a covalent bond between the combining atoms when the values of electronegativity of the two atoms are equal; the bond formed between them is almost a pure covalent bond. However, the formation of a covalent bond is also possible between two dissimilar atoms possessing different values of electronegativity. In such cases, the covalent bond is not pure and contains some ionic character or polarity.

#### Partial-ionic character in a covalent bond

Electronegativity is the measure of the tendency of an atom to pull shared electrons towards its own side in a covalent bond. When a covalent bond is formed between two atoms of the same element. The pull of two atoms on the shared pair is equal and the shared pair lies exactly in the middle of the nuclei of two atoms. In other words, the electron cloud constituting the covalent bond is symmetrically distributed around the two atoms as shown in the figure. In such cases, the covalent bond is almost pure. This is called a nonpolar covalent bond. Some examples of molecules containing non-polar covalent bonds are  $\text{H}_2, \text{Cl}_2, \text{O}_2, \text{N}_2, \text{F}_2, \text{Br}_2$ , etc.

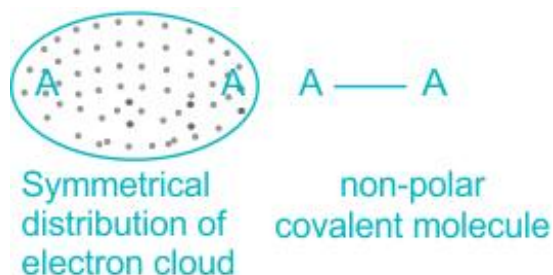

When a covalent bond is formed between two atoms of different elements having different electronegativities the atom with a higher value of electronegativity tries to pull the shared pair to a great extent towards itself as compared to the atom with the lower value of electronegativity. As a result of this, the shared pair of electrons gets shifted towards the more electronegative atom. The electron cloud constituting the covalent bond is no longer symmetrical around the two atoms and gets distorted.

The cloud is denser around the more electronegative atom. Thus a difference in the electronegativity of the combining atoms distorts the electron cloud and charge clouds get unevenly distributed. On account of this, the more electronegative atom acquires partial

negative charge (shown as  $-\delta$ ) and the less electronegative atom acquires partial positive charge (shown as  $+\delta$ ). The covalent bond thus develops a partial ionic character.

Such a covalent bond is referred to as a polar covalent bond or partially ionic covalent bond the molecules possessing such bonds are known as polar covalent molecules or simply polar molecules. For example, HF is a polar molecule.



H-F bond is a polar covalent bond due to unequal sharing of electrons between more electronegative F and less electronegative H atoms.



A molecule having partial positive and negative charges separated by a distance (bond distance) is referred to as a dipole (having two poles). The extent of ionic character in a covalent bond depends upon the difference in the electronegativities of the two atoms forming a bond. The larger the difference in the electronegativities of the combining atoms, the greater is the ionic character of the covalent bonds and consequently greater is the polarity in the molecule. A difference of 1.7 in the electronegativities of the combining atoms produces an ionic character of about 50% in the covalent bond.

### Dipole Moment

The polarity of covalent bonds can be conveniently measured in terms of a physical quantity called a dipole moment. It is represented by a Greek letter  $\mu$  (mu) and may be defined as follows.

It is the product of the magnitude of the charge and the distance between the centres of positive and negative charges.

$$\mu = Q \times r$$

Here Q is charge and r is the distance.

### Units of Dipole Moment

Dipole moment is expressed in the Debye unit (D). The conversion factor is

$$1 \text{ D} = 3.33564 \times 10^{-30} \text{ cm}$$

Where C is coulomb and m is metre. Dipole moment is a vector quantity and it is depicted by a small arrow with a tail on the positive centre and head pointing towards the negative centre.

In polyatomic molecules, the dipole moment depends upon the bond dipole and the spatial arrangement of various bonds in the molecules. In such cases, the dipole moment of a molecule is the vector sum of the dipole moments of various bonds.

Consider an example of  $\text{H}_2\text{O}$

It has a bent structure; the two O-H bonds are oriented at an angle of  $104.59^\circ$

Net dipole moment  $6.17 \times 10^{-30} \text{ cm}$  is the resultant dipole moment of two O-H bonds.

Net Dipole Moment,

$$\mu = 1.85 \text{ D} = 1.85 \times 3.33564 \times 10^{-30} \text{ cm} = 6.17 \times 10^{-30}$$

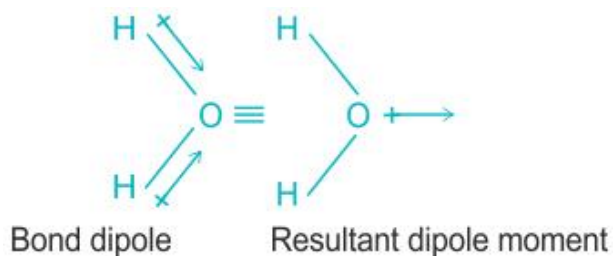

The higher the difference in electronegativities of the two atoms, the greater is the dipole moment of the diatomic molecule. This is why the dipole moment of HF is greater than that of HCl.

In a linear molecule, the two polar covalent bonds are oriented in the direction at an angle of  $180^\circ$ . Therefore, the two bond dipoles act in opposite directions and cancel each other.

The dipole moment in the case of  $\text{BeF}_2$  is zero



Bond dipole in  $\text{BeF}_2$ , Total dipole moment in  $\text{BeF}_2$ . Same is in the case of  $\text{CO}_2$

In a tetra atomic molecule, for example,  $\text{BF}_3$ ; the dipole moment is zero although the B-F bonds are oriented at an angle of  $120^\circ$  to one another. Here three bond moments give the net sum of zero as the resultant of any two is equal and opposite to the third.



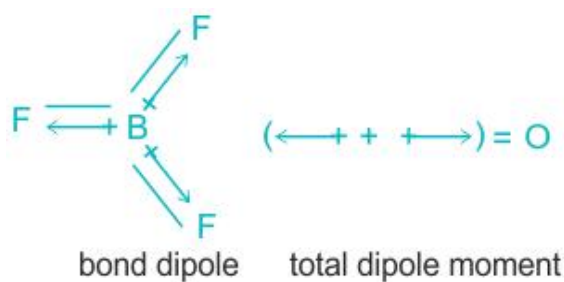

Consider the cases of  $\text{NH}_3$ , and  $\text{NF}_3$ . Both the molecules are having pyramidal shapes.

Lone pair is available on nitrogen in each molecule. Here, fluorine is more electronegative than nitrogen. The resultant dipole moment of  $\text{NH}_3$  is  $4.90 \times 10^{-30} \text{cm}$ . while that of  $\text{NF}_3$ , is  $0.80 \times 10^{-40} \text{cm}$ . This difference is because, in the case of  $\text{NH}_3$ , the orbital dipole due to the lone pair is in the same direction as the resultant dipole moment of N-H bonds hence gets added.

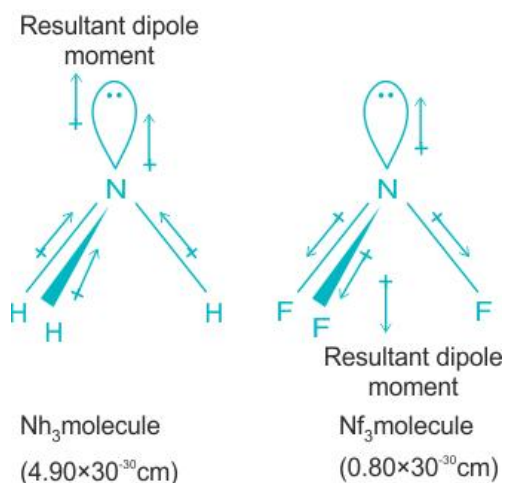

whereas in  $\text{NF}_3$ , the orbital dipole moment is in the direction opposite to the resultant dipole moment of three N-F bonds. The orbital dipole because of the lone pair decreases the effect of the resultant N-F bond moments, which results in the low dipole moment of  $\text{NF}_3$

Thus, the dipole moment is an important tool to decide the geometry of molecules possessing bond dipoles.

- ▲ In  $\text{CH}_3\text{Cl}$ , each Hydrogen atom has one valence electron and it requires one electron to complete its duplet ( since H is a s-block element it need maximum of two electrons in the outermost shell to attain stability ).
- ▲ Chlorine also has seven valence electrons and it requires one electron to complete the octet (the tendency of atoms to have eight electrons in the valence shell to attain stability). Carbon forms four single covalent bonds by sharing one electron with three hydrogen atoms( that is, three C-H bonds) and one electron with a Chlorine atom ( that is,C-Cl one bond).

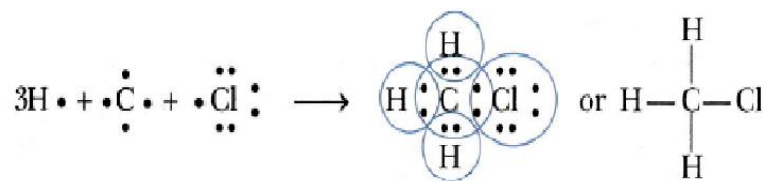

- ⤴ Chlorine (Cl) has comparatively huger size than carbon (C) and needs just one electron to fill its valence shell and be stable, so Cl is more electronegative than Carbon.
- ⤴ As the difference in electronegativity between chlorine and carbon is huge (since chlorine is more electronegative than carbon), the bond is polar in nature

Therefore in CH<sub>3</sub>Cl, Carbon forms four covalent bonds by sharing each of the four electrons with each of the three hydrogen atoms and one chloride atom. Since chlorine is more electronegative than carbon the C-Cl bond is polar in nature.

# **UNIT IV- STRUCTURE AND**

## **BONDING-II**

### **Valence Bond theory**

Valence Bond Theory was the first quantum mechanical treatment to account for chemical bonding. This theory was first introduced by Heitler and London in 1927 and subsequently by Slater and Pauling in 1930s. It is sometimes referred to as Heitler-London-Slater- Pauling (HLSP) theory.

VBT draws on the Lewis concept of a covalent bond as a shared pair of electrons (electron pair bond) i.e., valence bond approach is similar to the concept of

valence bond between two atoms. In this method, a molecule is considered as a collection of atoms and the interactions between different atoms.

**The theory utilizes the following wave mechanical properties:**

- i.  $\psi_A$  &  $\psi_B$  are wave function for any two completely independent systems A and B, then the total wave function  $\psi$  for these independent systems, taken together
 
$$\psi = \psi_A + \psi_B$$

Total energy E of these non interacting system would be equal to the sum of the energies of systems A and B

$$E = E_A + E_B \quad \hat{H} = \hat{H}_A + \hat{H}_B$$

- ii. Wave function for many electron systems has characteristics of several wave functions

$\psi_1, \psi_2, \psi_3, \dots, \psi_n$ . According to the Ritz principles of linear combination.

The wave function  $\psi$  closest to the true wave function of the system

$$\Psi = C_1 \psi_1 + C_2 \psi_2 + C_3 \psi_3 + \dots + C_n \psi_n$$

### Basic Assumption of VB Theory:

- i. Atoms do not lose their identity even after the formation of the molecule.
- ii. Inner electrons do not participate in the bond formation. Only the valence electrons come to each other.
- iii. During bond formation only the valence electrons from each bonded atom lose their identity. Other electrons remain unaffected.
- iv. Formation of bond is accompanied by release of energy;
- v. Larger the decrease in energy, stronger will be the bond formed.

### Postulates of VBT

The main postulates of this theory are as follows:

- i. Overlapping of two half-filled valence atomic orbitals of two different atoms results in a covalent bond.
- ii. The electrons in the overlapping orbitals get paired, localized and concentrated between the nuclei of two atoms.
- iii. Only two electrons with their spins paired may be shared by one set of overlapping orbitals.
- iv. The electron density between two bonded atoms increases due to overlapping. This confers stability to the molecule.
- v. The strength of the bond is directly proportional to the extent of overlap. Greater the extent of overlapping, stronger is the bond formed.
- vi. The direction of the covalent bond is along the region of overlapping of the atomic orbitals i.e., covalent bond is directional.

### VBT of Hydrogen molecule

It is important to note that VBT cannot solve Schrödinger equation for hydrogen molecule ion as VBT approximation

considers overlapping of atomic orbitals each with one electron respectively. And hydrogen molecule ion contains only one electron. For this reason, hydrogen molecule ion cannot be explained by VBT.

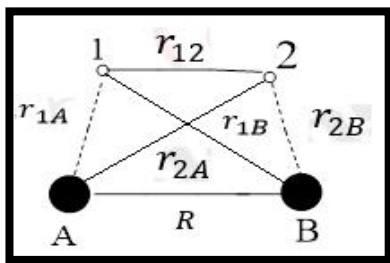

Let us now consider the simplest case of chemical bond, i.e., the hydrogen molecule  $H_2$  which has two nuclei and two electrons. Two hydrogen atoms A and B approaching each other having nuclei  $H_A$  and  $H_B$  and corresponding electrons  $e_A$  &  $e_B$ . When the two atoms are at large distance from each

other, no interaction between the two atoms takes place. At this stage Total energy of the System is the sum of the energies of the individual atoms. When two atoms come closer – New attractive and repulsive forces begin to operate.

#### **ATTRACTIVE FORCES:**

It operates between electron of atom A ( $e_A$ ) and Nucleous B ( $H_B$ ) and electron of atom B ( $e_B$ ) & Nucleous A ( $H_A$ ).

- ▲ Nucleous of one atom & its own electron  $H_A-e_A$  &  $H_B-e_B$ .
- ▲ Nucleous of one atom & electron of other atom  $H_A-e_B$  &  $H_B-e_A$ .
- ▲ To bring the atoms closer.

#### **REPUSIVE FORCES:**

It present between the two Nuclei  $H_A-H_B$  and electrons of two atoms  $e_A-e_B$ .

- ▲ Electrons of two atoms  $e_A-e_B$ .
- ▲ Nuclei of two atoms  $H_A-H_B$ .
- ▲ To push them apart.
  - The magnitude of the new attractive force is more than new repulsive forces.
  - Two atoms approach each other & the potential energy of the system decreases.
  - The two atoms are come closer and closer. The system becomes more and more stable due to decrease of energy.

#### **Resonance Concept**

Resonance structures are sets of Lewis structures that describe the delocalization of electrons in a polyatomic ion or a molecule. In many cases, a single Lewis structure fails to explain the bonding in a molecule/polyatomic ion due to the presence of partial charges

and fractional bonds in it. In such cases, resonance structures are used to describe chemical bonding.

### Conditions/Rules for writing resonance structure:

- i. The contributing structures should have the same atomic positions. They should differ only in the position of electrons.
- ii. The contributing structure should have the same number of unpaired electrons.
- iii. The contributing structures should not differ much in energy.
- iv. Contributing structures should be such that negative charge resides on an electronegative element and positive charge resides on an electropositive element.
- v. In contributing structure like charges should not reside on atoms close to each other and unlike charges should not be widely separated.

### Resonating Structures

Resonance in chemistry could be a manner of describing the bonding in particular molecules or ions by merging many contributory structures or forms, jointly called canonical structures or resonance structures within the theory of valence bonding into a hybrid resonance (or hybrid structure).

### Resonance Structures of Carbonate ( $\text{CO}_3^{2-}$ ) Ion

Carbonate ion is a common polyatomic ion found in limestone, baking powder and baking soda. Addition of acid to the carbonate ion causes the formation of carbonic acid, which decomposes rapidly into water and carbon dioxide. In baking the carbon dioxide that is released causes bread to rise and make its texture lighter. The first attempt to draw the lewis dot structure of the carbonate ion results in the structure shown below. Carbonate has 24 electrons, 2 of them responsible for the -2 charge, probably electrons from calcium, sodium or whatever salt resulted in a cation that donated electrons to the carbonate anion. The carbon atom in pure structure still needs to share electrons to satisfy the octet rule. Which atom is most likely involved in sharing electrons.

Using the formal charges on the atoms, we could reconfigure our electrons to

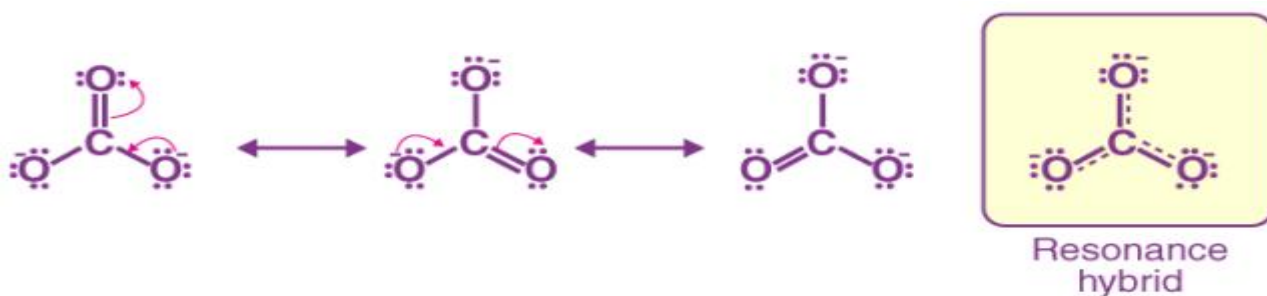



participate in a double bond with the carbon. At this point the positive charge on the carbon atom is gone and all the valence is filled; the octet rule is satisfied. The sum of the formal charges is equivalent to the charge on the carbonate ion. This is a good Lewis dot structure for carbonate. The different resonance structures of the carbonate ion ( $\text{CO}_3^{2-}$ ) are illustrated above. The delocalization of electrons is described via fractional bonds (which are denoted by dotted lines) and fractional charges in a **resonance hybrid**. Sometimes resonance structures are not equivalent, and it is important to determine which one(s) best describe the actual bonding. Formal charge can be used to predict which resonance structures are favored.

### Resonance Structures of $\text{NO}_2^-$ Ion

In the nitrite ion, the bond lengths of both nitrogen-oxygen bonds are equal. The Lewis dot structures of  $\text{NO}_2^-$  highlight a difference in the bond order of the two N-O bonds. The resonance hybrid of this polyatomic ion, obtained from its different resonance structures, can be used to explain the equal bond lengths, as illustrated below.

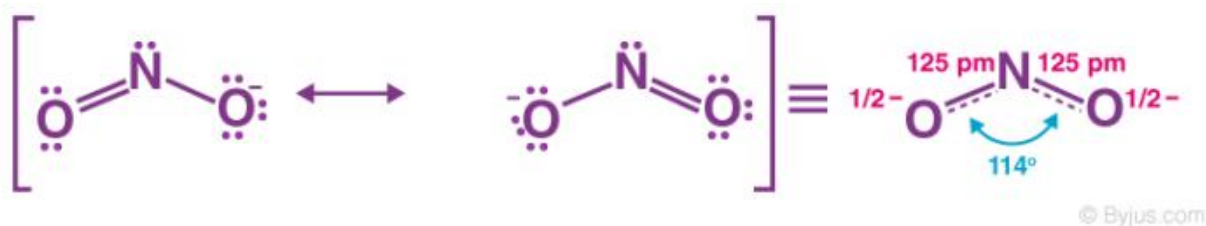

The resonance hybrid of  $\text{NO}_2^-$  suggests that each oxygen atom holds a partial charge of magnitude  $-\frac{1}{2}$ . The bond length of the N-O bonds is found to be 125 pm.

### Resonance Structures of $\text{NO}_3^-$ Ion

Nitrogen is the central atom in a nitrate ion. It is singly bonded to two oxygen atoms and doubly bonded to one oxygen atom. The oxygen atoms that are singly bonded to the nitrogen hold a charge of -1 (in order to satisfy the octet configuration). The central nitrogen atom has a charge of +1 and the overall charge on the nitrate ion is -1. The three possible resonance structures of  $\text{NO}_3^-$  are illustrated below.



If a resonance hybrid of this polyatomic ion is drawn from the set of Lewis structures provided above, the partial charge on each oxygen atom will be equal to  $-(\frac{2}{3})$ . The net charge on the central atom remains +1. This resonance hybrid is illustrated below.

### Resonance Structures of $O_3$

The ozone ( $O_3$ ) molecule consists of a central oxygen atom which is singly bonded to one oxygen atom and doubly bonded to another. There is no net charge on this molecule, but the Lewis structures of this molecule show a +1 charge on the central oxygen and a -1 charge on the singly bonded oxygen. The two resonance structures of the ozone molecule are illustrated below.

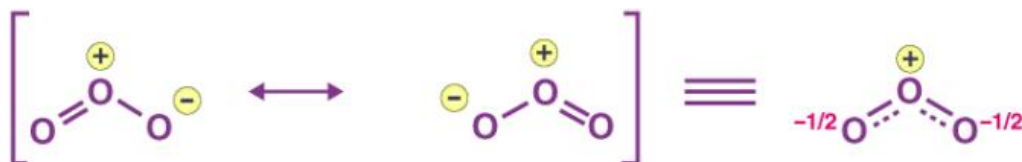

The resonance hybrid of ozone has a +1 charge associated with the oxygen at the centre and a partial charge of  $-(\frac{1}{2})$  associated with the other oxygen atoms.

### Resonance Structures of Carbon dioxide, or $CO_2$

It has three resonance structures, out of which one is a major contributor. The  $CO_2$  molecule has a total of 16 valence electrons - 4 from carbon and 6 from each oxygen atom. Here are the three resonance structures for  $CO_2$ , all accounting for the 16 valence electrons. Carbon dioxide molecules consist of one carbon atom and two oxygen atoms. It has two double bonds between the carbon and oxygen atom. Each double bond is made of one sigma and one pi bond. In the entire carbon dioxide molecule contains two sigma and two pi bonds.

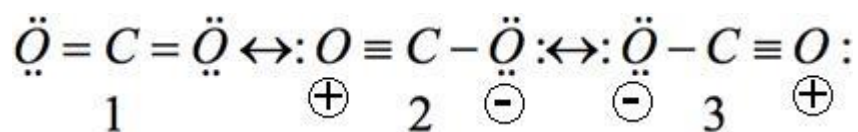

The atoms in all three resonance structures have full octets; however, structure 1 will be more stable, and thus contribute more, because it has no separation of charge. Structures 2 and 3 show charge separation caused by the presence of formal charges on both oxygen atoms. Moreover, the presence of a positive charge on oxygen further reduces the stability of these two structures.

### **Limitations of Valence bond theory:**

- ⤴ While it provides a qualitative depiction of the complex, it does not provide a quantitative interpretation of the complex's stability.
- ⤴ It does not account for the complexes spectra (colour).
- ⤴ It predicts no distortion in symmetrical compounds, but predicts distortion in all copper (II) and titanium (III) complexes.
- ⤴ It provides no specific information regarding the complexes' magnetic characteristics. It cannot, for example, account for the complexes' temperature-dependent paramagnetism.
- ⤴ It does not explain why, at times, the electrons must be placed in contravention of Hund's rule, while at other times, the electrical configuration remains unaltered.
- ⤴ It fails to account satisfactorily for the occurrence of inner and outer orbital complexes.
- ⤴ Occasionally, the theory requires electrons to be transferred from a lower energy level (Example 3d) to a higher energy level (4p), which is highly implausible in the absence of a source of energy.
- ⤴ Electron spin resonance demonstrates that the electron is not in the 4p level in Cu(II) complexes, indicating that the complex is planar.
- ⤴ It is unable to account for why some complexes are more labile than others. Complexes that are labile are those in which one ligand can be easily displaced by another. Inert complexes, on the other hand, are ones in which ligand displacement is sluggish.

### **Molecular orbital theory**

Molecular orbital theory (often abbreviated to MOT) is a theory on chemical bonding developed at the beginning of the twentieth century by F.Hund and R. S. Mulliken to describe the structure and properties of different molecules. The valence-bond theory

failed to adequately explain how certain molecules contain two or more equivalent bonds whose bond orders lie between that of a single bond and that of a double bond, such as the bonds in resonance-stabilised molecules. This is where the molecular orbital theory proved to be more powerful than the valence-bond theory (since the orbitals described by the MOT reflect the geometries of the molecules to which it is applied).

### Salient features

- i. Atom, molecule has orbitals of definite energy levels electrons of atoms are present in atomic orbitals. Electrons of a molecules are present in different molecular orbitals.
- ii. Molecular orbitals are formed by the combination of atomic orbitals of proper symmetry and comparable energies.
- iii. An electron in an atomic orbital is under the influence of only one nucleous. electron in a molecular orbital is under the influence of two (or) more nuclei depending upon the number of atoms present in the molecule. Atomic orbital is mono centric, molecular orbital is polycentric.
- iv. Just as the electron probability distribution around a nucleous in an atom is given by an atomic orbital the electron probability distribution around a group of nuclei in a molecule is given by molecular orbital.
- v. The number of molecular orbital formed is equal to the number of combining atomic orbitals. Two atomic orbitals combined, they form two molecular orbitals , these are called bonding & anti-bonding molecular orbitals.
- vi. Bonding MO has lower energy and hence greater stability where as corresponding anti-bonding MO has more energy & hence lesser stability.
- vii. Molecular orbitals are filled in same way as atomic orbitals are filled in accordance with aufbau principle, pauli exclusion principle and hunds rule.

### Difference between Bonding Molecular orbital and Anti -Bonding Molecular Orbital

| Bonding MO  | Anti-bonding MO   |
|---|---|
| It's formed by the addition of overlapping of atomic orbitals. The wave function of the | It is formed by the subtraction of overlapping of atomic orbitals. The wave |

|   |  |
|---|--|
| bonding MO may be written as<br>$\psi(\text{MO}) = \psi_A + \psi_B$                   | function for the Anti-bonding MO may be written as $\psi^*(\text{MO}) = \psi_A - \psi_B$ |
| They are formed when the lobes of the combining atomic orbitals have same sign.       | They are formed when the lobes of the combining atomic orbitals have opposite sign.      |
| It has greater electron density in the region between the two nuclei of bonded atoms. | It has lesser e- density in the region b/w the two nuclei of the atoms.                  |
| It possesses lower energy than the isolated atomic orbitals.                          | It possesses higher energy than the isolated atomic orbitals.                            |
| The electrons in the bonding MO contributes to attraction b/w the two atoms.          | The electrons in Anti-bonding MO contribute to repulsion b/w two atoms.                  |

**The key features of the molecular orbital theory are listed below.**

- ▲ The total number of molecular orbitals formed will always be equal to the total number of atomic orbitals offered by the bonding species.
- ▲ There exist different types of molecular orbitals: bonding molecular orbitals, anti-bonding molecular orbitals and non-bonding molecular orbitals. Of these, anti-bonding molecular orbitals will always have higher energy than the parent orbitals, whereas bonding molecular orbitals will always have lower energy than the parent orbitals.
- ▲ The electrons are filled into molecular orbitals in the increasing order of orbital energy (from the orbital with the lowest energy to the orbital with the highest energy).
- ▲ The most effective combinations of atomic orbitals (for the formation of molecular orbitals) occur when the combining atomic orbitals have similar energies.

- ▲ Molecular orbital theory approximation of the molecular orbitals as linear combinations of atomic orbitals can be illustrated as follows.

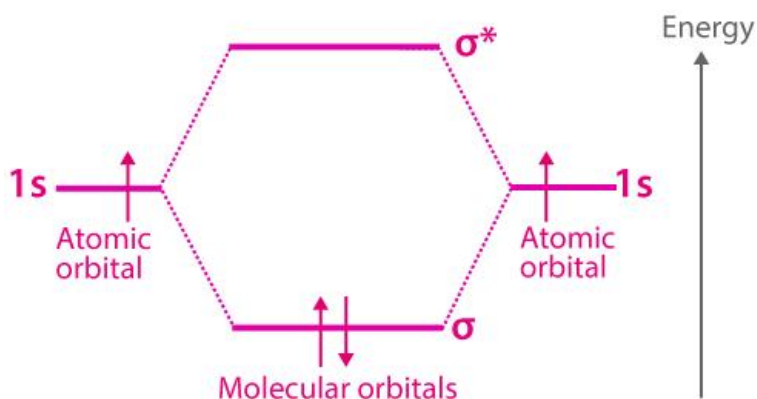

However, to understand the molecular orbital theory more clearly and in-depth, it is important to understand what atomic and molecular orbitals are first.

### Types of Molecular Orbitals

According to the molecular orbital theory, there exist three primary types of molecular orbitals that are formed from the linear combination of atomic orbitals. These orbitals are detailed below.

- ▲ **Bonding Molecular Orbitals**

Electrons are considered to move between the nuclei of the two atoms. So, the electron density is high in the bonding molecular orbital. It is formed by the addition overlap of atomic orbitals.

The energy of the bonding molecular orbital is lower than the combining atomic orbitals.

### ⤴ **Anti Bonding Molecular Orbitals**

The electron density is concentrated behind the nuclei of the two bonding atoms in anti-bonding molecular orbitals. This results in the nuclei of the two atoms being pulled away from each other. These kinds of orbitals weaken the bond between two atoms. In anti bonding molecular orbital, electrons are considered to move outside the nuclei of the two atoms

### ⤴ **Non-Bonding Molecular Orbitals**

In the case of non-bonding molecular orbitals, due to a complete lack of symmetry in the compatibility of two bonding atomic orbitals, the molecular orbitals formed have no positive or negative interactions with each other. These types of orbitals do not affect the bond between the two atoms.

## Formation of Molecular Orbitals

An atomic orbital is an electron wave; the waves of the two atomic orbitals may be in phase or out of phase. Suppose  $\Psi_A$  and  $\Psi_B$  represent the amplitude of the electron wave of the atomic orbitals of the two atoms A and B.

- ⤴ **Case 1:** When the two waves are in phase so that they add up and the amplitude of the wave is  $\Phi = \Psi_A + \Psi_B$
- ⤴ **Case 2:** When the two waves are out of phase, the waves are subtracted from each other so that the amplitude of the new wave is  $\Phi' = \Psi_A - \Psi_B$

### Characteristics of Bonding Molecular Orbitals

- i. The probability of finding the electron in the internuclear region of the bonding molecular orbital is greater than that of combining atomic orbitals.
- ii. The electrons present in the bonding molecular orbital result in the attraction between the two atoms.
- iii. The bonding molecular orbital has lower energy as a result of attraction and, hence, has greater stability than that of the combining atomic orbitals.
- iv. They are formed by the additive effect of the atomic orbitals so that the amplitude of the new wave is given by  $\Phi = \Psi_A + \Psi_B$
- v. They are represented by  $\sigma$ ,  $\pi$ , and  $\delta$ .

### Characteristics of Anti-bonding Molecular Orbitals

- ▲ The probability of finding the electron in the internuclear region decreases in the anti-bonding molecular orbitals.
- ▲ The electrons present in the anti-bonding molecular orbital result in the repulsion between the two atoms.
- ▲ The anti-bonding molecular orbitals have higher energy because of the repulsive forces and lower stability.
- ▲ They are formed by the subtractive effect of the atomic orbitals. The amplitude of the new wave is given by  $\Phi' = \Psi_A - \Psi_B$  They are represented by  $\sigma^*$ ,  $\pi^*$ ,  $\delta^*$

### Relationship Between Electronic Configuration and Molecular Behaviour

#### i. Molecule stability in terms of bonding and antibonding electrons.

The number of electrons in bonding orbitals is represented by  $N_b$ , while the number of electrons in antibonding orbitals is represented by  $N_a$ .

- If  $N_b > N_a$  molecule is stable
- If  $N_b < N_a$  molecule is unstable
- If  $N_b = N_a$  molecule is unstable

#### ii. Molecule stability in terms of bond order.

Bond order is defined as half the difference in the number of electrons in the bonding and antibonding orbitals.

$$\text{Bond order} = \frac{1}{2} (N_b - N_a)$$

If  $N_b > N_a$ , the molecule is stable; otherwise, it is unstable.



iii. **Bond nature in terms of bond order.**

Bond orders 1, 2, and 3 denote single, double, and triple bonds, respectively.

iv. **Bond length in relation to bond order.**

The length of a bond is found to be inversely proportional to its order.

v. **The molecule's diamagnetic and paramagnetic properties.**

It is diamagnetic if all of the electrons in the molecule are paired.

If a molecule contains some unpaired electrons, it is paramagnetic.

**Molecular orbital diagram of H<sub>2</sub> Molecule**

- The electronic configuration of H<sub>2</sub> is  $\sigma(1s^2)$ .  
 $N_b = 2, N_a = 0$ .
- $\therefore$  Bond order = 1,
- The molecule is stable since it is a positive value.
- The two hydrogen atoms are connected by a single bond.
- Since there are no unpaired electrons, the H<sub>2</sub> molecule is diamagnetic.

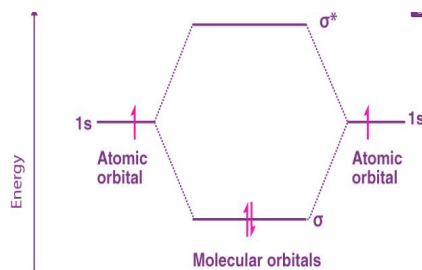

**Molecular orbital diagram of Nitrogen molecule**

- The total number of electrons present in the N<sub>2</sub> molecule is 14.
- Number of electrons in bonding orbitals : 8
- Number of electrons in antibonding orbitals : 2  
Bond order = (Number of electrons in BMO) - (Number of electrons in ABMO)/2  
Bond order = (8) - (2)/2  
Bond order = 3
- N<sub>2</sub> molecules are diamagnetic, with no unpaired electrons.

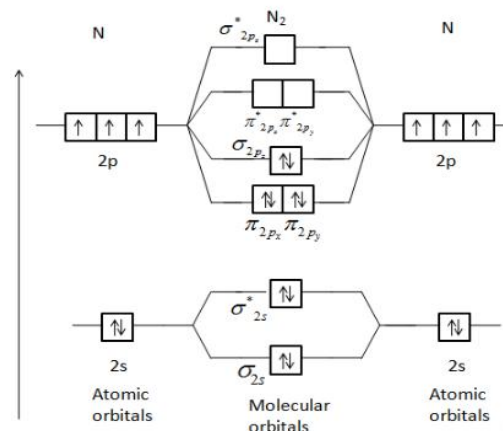

**Molecular orbital diagram of oxygen molecule:**

- Atomic number of oxygen – 8
- Electronic configuration –  $1s^2 2s^2 2p^4$
- Total number of electrons in  $N_2$  molecule – 16
- **Electronic configuration of oxygen molecule;**
- $\sigma 1s^2 < * \sigma 1s^2 < \sigma 2s^2 < * \sigma 2s^2$ ,
- $[\pi 2p_x^2 = \pi 2p_y^2] < \sigma 2p_z^2 < [* \pi 2p_x^1 = * \pi 2p_y^1] < * \sigma 2p_z$
- Let's calculate the bond order of  $O_2$ ;  
Bond order = Bonding – Anti bonding electrons / 2  
 $= 10 - 6 / 2 = 2$  The order of  $O_2$  is 2.

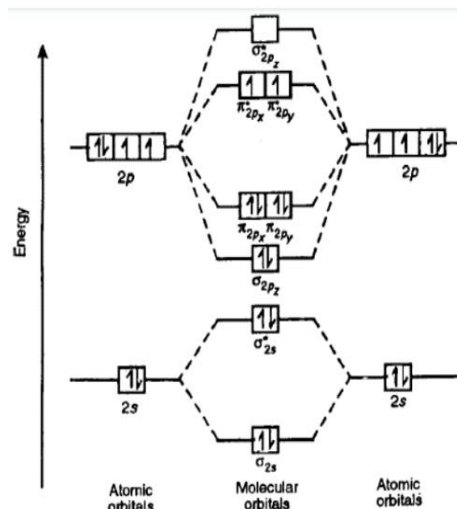

- $O_2$  have unpaired electrons, Hence it is Paramagnetic.

#### For $O_2^+$ molecule,

An electron is removed from  $* 2p_y$  orbital.

Bond order =  $10 - 5 / 2 = 2.5$ , Paramagnetic.

#### For $O_2^-$ molecule,

An electron is added to  $\pi^*$  &  $\pi 2p_x^1$  orbital.

$\therefore$  Bond order =  $10 - 7 / 2 = 1.5$ , Para magnetic

#### ▲ For $O_2^{2-}$ molecule,

Two electrons are added to  $\pi 2p_x^1$  and  $* 2p_{y1}$  orbitals.

$\therefore$  Bond order =  $10 - 8 / 2 = 1$ , Diamagnetic

So, the order is:

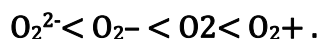

#### The molecular orbital diagram for $C_2$ molecule is:

- The electronic configuration of  $C_2$  is  $(\sigma 2s)^2 (\sigma^* 2s)^2 (\pi 2p_x)^2 (\pi 2p_y)^2$
- The  $C_2$  molecule is diamagnetic because all electrons are paired there are no unpaired electrons.

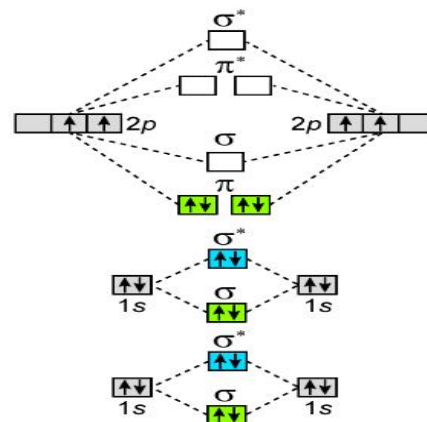

#### The molecular orbital diagram for Carbon monoxide molecule:

- Electronic configuration of C atom:  
 $1s^2 2s^2 2p^2$
- Electronic configuration of O atom:  
 $1s^2 2s^2 2p^4$
- Electronic configuration of CO molecule:  
 $\sigma 1s^2 \sigma^* 1s^2 \sigma 2s^2 \sigma^* 2s^2 \pi 2p_y^2 \pi 2p_z^2 \pi 2p_x^2$
- Bond order =  $N_b - N_a / 2 = 10 - 4 / 2 = 3$ .
- The molecule has no unpaired electrons hence it is diamagnetic.

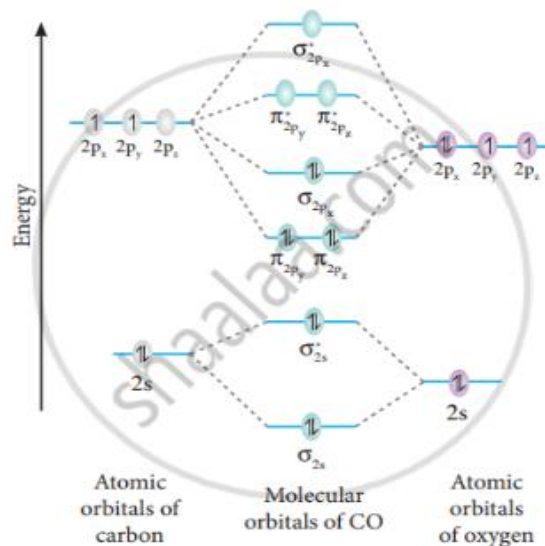

### The molecular orbital diagram for NO molecule

- The atomic number of N is 7 and the atomic number of O is 8.

The total number of electrons will be 15.

The electronic configuration of NO =

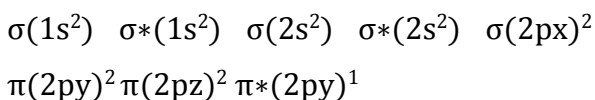

- It can be shown that one electron is unpaired.
- As a result, it's a paramagnetic substance.

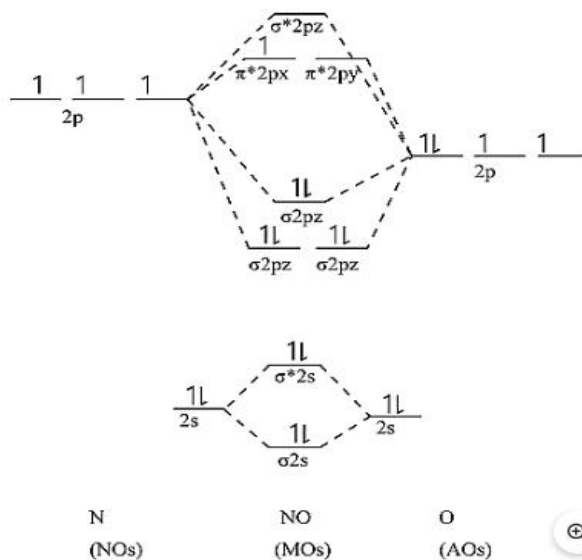

### **Bond order calculation:**

The number of bonds between two atoms is referred to as bond order. Linus Pauling was the one who first proposed it. The higher a bond's bond order, the more stable the bond. As a result, a single bond is weaker than a double bond, which in turn is weaker than a triple bond. The electrons are present in bonding orbitals and which are present in

antibonding orbitals are seen in a molecular orbital diagram. Bond order can also be expressed as a diffraction number in some situations.

Bond order = Bonding electron – non bonding electron /2

For example Bond order =  $10 - 5 / 2$

Bond order = 2.5

### The molecular orbital diagram for HF molecule

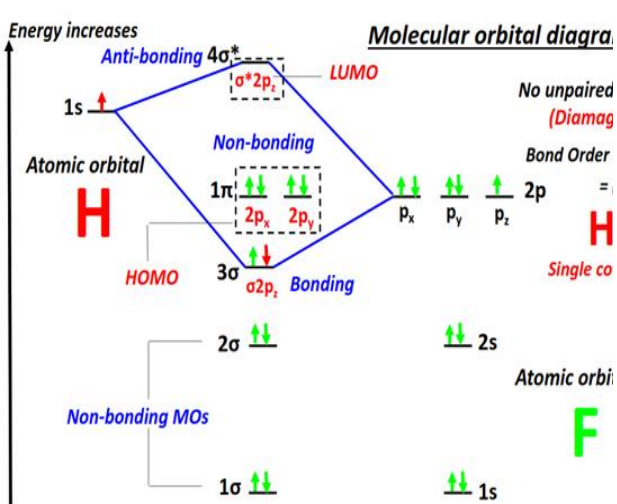

▲ HF comprises a hydrogen (H) atom and a fluorine (F) atom.

▲ The electronic configuration of an H-atom is  $1s^1$ .

▲ The electronic configuration of F-atom is  $1s^2 2s^2 2p^5$ .

▲ 9 electrons of fluorine and 1 hydrogen electron make a total of  $9 + 1 = 10$  electrons available to be filled in the Molecular orbital diagram of HF.  $(1\sigma^2)(2\sigma^2)(3\sigma^2)(1\pi^4)$

▲ Bond Order =  $2 - 0 / 2 = 1$

▲ HF molecule is Diamagnetic

### Comparison between MO Theory and VB Theory

#### Common between MO Theory and VB Theory

- The basic principles in the distribution of electrons are similar atomic (or) molecular cannot have more than 2 electrons. They are filled in the order of increasing energy, if there is more than one.
- In covalent bond formation, the essential interaction, according to both the theories is the sharing of the bonding electron charge density by both nuclei and concentration of electron charge density between the nuclei.
- In bond formation, the orbitals of the bonding atoms must overlays to each other for the both the theories.

- The energies of the overlapping orbitals, are to the theories must be comparable and their symmetries should be the same.

### Differences

- VBT starts with individual atoms and does not consider the interaction between them, MOT starts with the Nuclei of the constituent atoms.
- VBT only the half filled orbitals of the valence shell take  $\phi$  cost in bonding and the remaining orbitals retain their identity. MOT all the atomic orbitals whether filled (or) unfilled, would overlay to form molecular orbitals. By providing proper symmetry and comparable energy.
- The wave function in original VBT does not give any weight-age to ionic structure. MOT inherently gives equal weight-age to covalent and ionic structure.
- While VBT fails to account for the paramagnetic character of oxygen MOT offers a satisfactory explanation.
- While resonance plays an important role in VBT, this concept has no place in MOT.
- MOT is more exact than the VBT however, the calculations involved in MOT are much more tedious than those involved in VBT.

### Co-ordinate bond

**Co-ordinate covalent bond:-** Electrons for sharing between the atoms are contributed by one atom only.

#### Characteristic of co-ordinate covalent bond

- The atom that shares an electron pair from itself is termed as the donor.
- Other atom which accepts the shared pair of electrons is known as an acceptor (or) acceptor.
- The bond is represented with an arrow  $\rightarrow$  pointing towards the acceptor from the donor atom.
- After sharing of electron pairs, each atom gets stability.
- This type of bonding is central to the Lewis theory.
- Co-ordinate covalent bonds can help in properly designing complex organic molecules.

#### Formation of Ammonium ions

When a neutral ammonia compound  $\text{NH}_3$  is protonated or takes on an additional positively charged hydrogen atom, an ammonium ion is formed.”

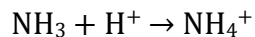

In ammonia, nitrogen is a central atom with 5 electrons in its valence shell, 3 of which are shared with 3-H atoms, and 1 lone pair of electrons completes the valence shell configuration.

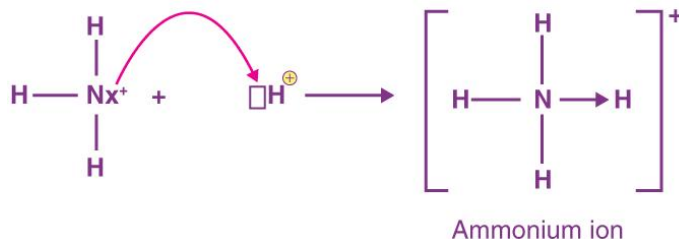

It is an electron-rich species (nucleophile) because it has one lone pair electron (unshared electron pair) and can donate this electron pair to another atom (electrophile). As a result, ammonia is a donor, and when the Ammonia atom donates its lone pair to the proton ammonium ion is formed.

Ammonium ions  $\text{NH}_4^+$  are formed by the transfer of hydrogen ion from the HCl molecule to the lone pair of electrons on the  $\text{NH}_3$  molecule.

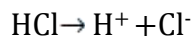

### **Formation of Hydronium ion:**

Oxygen atom in water donates its one pair of electron to the vacant orbital of  $\text{H}^+$  ion, thus a dative bond is formed oxygen atom is the donar atom and the  $\text{H}^+$  is the accept on atom.

When a protic acid is added to water, it releases a hydrogen ion ( $\text{H}^+$ ) (also called a proton because a hydrogen atom missing one electron is nothing but a proton!). However,  $\text{H}^+$  will not stay a free ion, and instead immediately combines with a nearby water molecule ( $\text{H}_2\text{O}$ ) to form the hydronium ion,  $\text{H}_3\text{O}^+$ . For example, when hydrochloric acid (HCl) is added to water, the following reaction occurs:



### Formation of Ammonia Borontrifluoride:

N atom in  $\text{NH}_3$  donates one pair of electrons to the vacant orbital of the Boron atom in the  $\text{BF}_3$ . Thus N atom is the donor B is the acceptor.

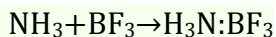

From the reaction it is clear that  $\text{BF}_3$  is accepting the electron pairs from  $:\text{NH}_3$ .

Although  $\text{BF}_3$  does not have a proton but acts as Lewis's acid as it is an electron deficient compound.

It reacts with  $\text{NH}_3$  by accepting the lone pair of electrons from  $\text{NH}_3$ , forming a co-ordinate bond and completes its octet.

Acids are electron pair acceptor and bases are electron pair donors. So,  $\text{BF}_3$  is a Lewis acid and  $\text{NH}_3$  is a Lewis base. So, Lewis theory of acids and bases explains it.

Hybridization Boron in  $\text{BF}_3$  is  $sp^2$  hybridized- as 3 orbitals i.e. 2s, 2px, 2py gets involved in bond formation, whereas N in  $\text{NH}_3$  is  $sp^3$  hybridized with 4 orbitals - 2s, 2px, 2py, 2pz involved

### PROPERTIES:

- Lower M.pt & B.pt than ionic compounds.
- Exhibit isomerism (some compounds).
- Sharing of electron takes place in a definite direction hence its a directional bond.
- It is weaker than ionic bonding.

### Metallic bonding

- Metals are crystalline in nature and forms metallic bond.
- Therefore it has high Melting and Boiling point.
- They have high electrical and thermal conductivities
- They have high Coordination number

### **Theories of Metallic Bonds**

- ▲ Free electron theory (or) Electron sea theory
- ▲ Valence Bond Theory (or) Resonance Theory
- ▲ Bond Theory (or) Molecular Orbital Theory

### Electron Sea theory:

- Theory was defined by scientist Drude and Lorentz based on two important properties
  - Unpaired electrons in valence cell
  - Low ionization energy of metal i.e, metal can lost electron more easily

### According to this theory,

- Metal lose its outermost electrons and converted into positive ions
- Thereby the structure consists of metal ion with +ve charge and free electrons.
- Metal with +ve charge called Kernels and free electrons are called Sea of electrons
- The combined force of attraction between Kernels and electron cloud is called metallic bond and is uniform in all direction
- It is different than that of covalent bond. Where as, metallic bond is non-directional and weaker than covalent bond
- The Strength of Metallic bond increases with increases in number of valence electrons.

Eg. Na<Mg<Al

### Properties of metals on the basis of free electron theory:

- *Electrical and Thermal Conductivities:*
  - ▲ This property depends on the number of Valence electrons in metal
  - ▲ When some potential is applied, then electron flow in the direction of applied field from one point to another. Therefore metals are good conductor of electricity
  - ▲ Similarly when piece of metal is heated at one end acquires heat energy, the electron present transfer from one end to other end. Therefore the metal are good conductor of heat
- *Malleability and Ductility*
  - ▲ The property of metals to form thin sheet on hammering is called as malleability
  - ▲ The property of metal to form wire is called Ductility



- ▲ NOTE: In metal structure, the metal ions are embedded in the sea of electrons. When the metal ion layers slide over each other and forms a thin sheet and electrons act as cushion and similarly wire can be obtained

➤ *Metallic Luster*

- ▲ The metals have typical shining luster. This is due to the presence of free electrons present in the metal
- ▲ When light is fall on clean surface of metal, the free electron absorbs light energy gets excited to higher energy level, But higher energy level is unstable and electrons can not stay longer time and immediately come back to ground state and re emitted in the form of light. This is responsible for shining luster.

**Valence Bond Theory or Resonance Theory:**

This theory was given by Pauling and considered as covalent bond between two metal atoms. The metal atom is surrounded by definite number of nearest metal atoms in metallic crystal lattice.

Example

- In lithium molecule, one Lithium atom is surrounded by 8 lithium (neighbour) atom. The lithium atoms are connected by covalent bond.
- Lithium has one valence electron ( $1s^2 2s^1$ ) where two lithium atoms share one electron each and forms single covalent bond
- The bond is not permanent, it immediately broken and a new bond is formed with other lithium atom.
- This means this bond is continuously resonating.
- Consider four lithium atom, it forms resonating bond

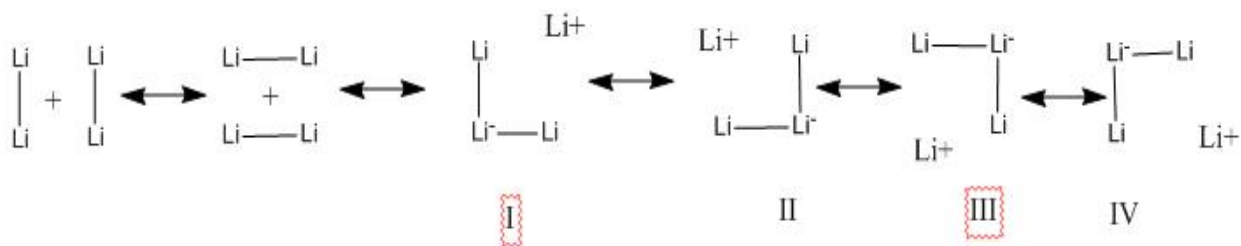

- These are the resonating structure
- But this theory fails to explain thermal and electrical conductivity and metallic luster.

## Molecular Orbital Theory (or) Bond theory:

### The band model of conductors

In conductors, the valence band is either not fully occupied with electrons, or the filled valence band overlaps with the empty conduction band. In general, both states occur at the same time, the electrons can therefore move inside the partially filled valence band or inside the two overlapping bands. In conductors there is no band gap between the valence band and conduction band.

All the electrons in the metal belong to metal atom in the metallic crystal. The set of large number of closely spaced molecules orbitals in a metallic crystal is called as band.

Note:

- When two atomic orbitals combined to form two new molecular orbital ie, one is bonding molecular orbital another is anti-bonding molecular orbital.
- On the metallic crystal, there are large numbers of metallic orbitals, combined to form large number of molecular orbital which are closely spaced called as band.

Example -1

- ▲ Lithium- Number of electron= $3(1s^2 2s^1 2p^0)$
- ▲ Three bands are available  $1s^2 =$  fully filled,  $2s^1 =$  Half filled,  $2p^0$ - Vacant or empty orbital
- ▲ Actually  $2p$  band overlap with  $2s$ . But there is energy gap between  $1s$  (filled) and  $2s$  (half filled) called forbidden in energy gap. Therefore the electrons are not allowed to go

Example -2

Beryllium : Number of electron= $4(1s^2 2s^2 2p^0)$

- Three bands are available  $1s^2$ ,  $2s^2 =$  fully filled,  $2p^0$ - Vacant or empty orbital
- The vacant  $2p$  orbital overlap with fully filled  $2s$  (Partial overlap)
- The lower energy state molecular orbital-Valence band
- The higher energy state molecular orbital- Conduction band
- In Beryllium  $2s \rightarrow$ Valence band;  $2p \rightarrow$ Conduction band

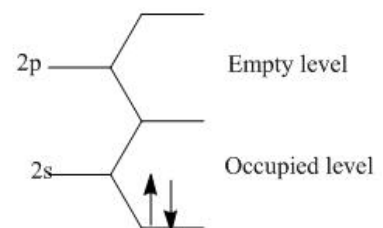

### **The band model of insulators**

In insulators the valence band is fully occupied with electrons due to the covalent bonds. The electrons cannot move because they're "locked up" between the atoms. To achieve conductivity, electrons from the valence band have to move into the conduction band. This prevents the band gap, which lies in-between the valence band and conduction band. Only with considerable energy expenditure (if at all possible) the band gap can be overcome; thus leading to a negligible conductivity.

### **The band model of semiconductors**

Even in semiconductors, there is a band gap, but compared to insulators it is so small that even at room temperature electrons from the valence band can be lifted into the conduction band. The electrons can move freely and act as charge carriers. In addition, each electron also leaves a hole in the valence band behind, which can be filled by other electrons in the valence band. Thus wandering holes in the valence band, this can be viewed as positive charge carriers. There are always pairs of electrons and holes, so that there are as many negative as positive charges, the semiconductor crystal as a whole is neutral. A pure undoped semiconductor is known as intrinsic semiconductor.

Since the electrons always assume the energetically lowest state, they fall back into the valence band and recombine with the holes if there is no energy supply. At a certain temperature equilibrium is arranged between the electrons elevated to the conduction band and the electrons falling back. With increasing temperature the number of electrons that can leap the band gap is increased, and thus increasing the conductivity of semiconductors.

### **Condition for electrical conductance:**

For conductance of electricity, when the potential difference is applied, the electron excited from lower energy lower energy molecular orbital to higher energy molecular orbitals of same or higher band.

This theory helps to explain the nature of conductors, Semiconductors and Insulators.

### **Conductors**

Conductors are generally substances which have the property to pass different types of energy.

➤ Metals

The conductivity of metals is based on the free electrons (so-called Fermi gas) due to the metal bonding. Already with low energy electrons become sufficiently detached from the atoms and conductivity is achieved.

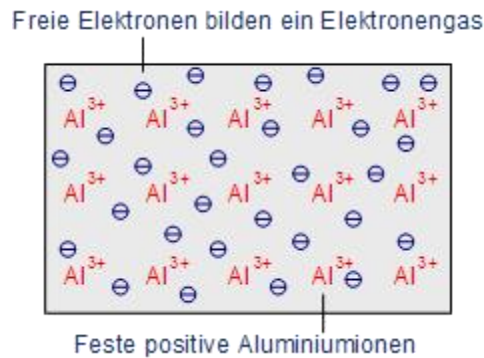

The conductivity depends on the temperature. If the temperature rises, the metal atoms swing ever stronger, so that the electrons are constrained in their movements. Consequence, the resistance increases. The best conductors, gold and silver, are used relatively rare because of the high costs (gold e.g. for the contacting of the finished chips). The alternatives in the semiconductor technology for the wiring of the individual components of microchips are aluminum and copper.

➤ Salts

In addition to metals, salts can also conduct electricity. There are no free electrons, so the conductivity depends on ions which can be solved when a salt is melting or dissolving, so that the ions are free to move.

### **Insulators**

Insulators possess no free charge carriers and thus are non-conductive.

➤ The atomic bond

The atomic bond is based on shared electron pairs of nonmetals. The elements which behave like nonmetals have the desire to catch electrons, thus there are no free electrons which might serve as charge carriers.

➤ The ionic bond

In the solid state, ions are arranged in a grid network. By electrical forces, the particles are held together. There are no free charge carriers to enable a current flow. Thus substances composed of ions can be both conductor and insulator.

## Semiconductors

A material is said to be a semiconductor if its conductivity is greater than that of the insulator and less than that of the conductor. That means the conductivity of the semiconductor lies between that of the insulator and the conductor. The energy band gap is the difference between the conduction band's lowest level and the valence band's highest level. That means the energy bandgap of the semiconductor lies between that of the conductor and insulator.

Semiconductors can be classified as:

- Intrinsic Semiconductor
- Extrinsic Semiconductor

### ▲ Intrinsic Semiconductor

Intrinsic semiconductors are called the purest form of semiconductors because there is no doping method involved here. Hence, Intrinsic semiconductors are also called as undoped or i-type semiconductors. The conductivity of intrinsic semiconductor depends upon the number of holes and electrons present in the atom itself, which are equal in numbers. The conductivity obtained by active electrons passing through these holes is called intrinsic conductivity.

### ▲ Extrinsic Semiconductor

Extrinsic semiconductors work exactly opposite of intrinsic semiconductors. In this process a small number of suitable replacement atoms called Impurities are added to the pure semiconductor known as doping. During this process, due to the presence of more electrons the conductivity increases.

### ▲ An extrinsic semiconductor can be further classified into:

- N-type Semiconductor
- P-type Semiconductor

### ▲ *N-Type Semiconductor:*

*In this type of semiconductor, impurities or also called as pentavalent are added in a pure semiconductor through the process called doping. When a semiconductor is doped with negative charged electrons, the number of electrons in that particular atom increases. But the number of holes in that atom remains the same. As a result, the negative charge of those atom increases thereby forming the name as n-type*

*semiconductor, where “n” stands for negative. The holes in n-type semiconductor are minority carriers and electrons as major carriers.*

▲ *P-Type Semiconductor:*

*In p-type semiconductor, the pentavalent is added to a pure semiconductor in the doping process. But here in p-type instead of electrons, holes have been added as an impurity. As a result the positive charge of that particular atom increases thereby giving the name as p-type semiconductor.*

Applications of Semiconductors:

- ▲ In Electronic Consumer goods such as mobile phones, calculators, laptops, refrigerators and microwaves.
- ▲ Semiconductors can also be observed in manual cars.
- ▲ Semiconductors are also used in Light Emitting Diode (LED's)

## UNIT-V: BASIC CONCEPTS IN ORGANIC CHEMISTRY AND ELECTRONIC EFFECTS

### Cleavage of Chemical Bonds

The breaking of chemical bond in the substrate during the reaction is called bond cleavage or bond fission. It is caused by electronic redistribution initiated by gain, loss or withdrawal of shared or lone pair by an atom in a chemical species. The factors like nature of atomic pair bonded, the groups attached to them, the reaction condition and attacking agent influence and promote bond cleavage.

Two modes of bond fission are

➤ Homolytic fission (homolysis):

The symmetric or even distribution of a covalent bond to form a pair of free radicals is called as homolytic bond fission or homolysis. In homolytic fission each atom withdraws its shared electron to break the bond and a pair of free radicals formed. As movement of single electron takes place so it is shown by *half headed arrow*. Homolytic fission normally occurs in gaseous phase in presence of light or heat. Organic reactions proceed by homolytic fission are called free radical or non polar reactions.

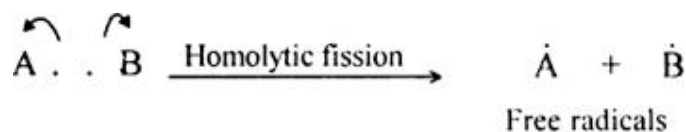

➤ Heterolytic fission (heterolysis):

The unsymmetric or uneven breaking of a covalent bond to form a pair of oppositely charged ions is called as heterolytic bond fission or heterolysis. As movement of pair electrons takes place so it is shown by *double headed arrow*. In heterolytic fission the more electronegative atom takes up both the shared electrons, so it carries negative charge with complete octet, while more electropositive atom carries positive charge with sextet of electrons. Organic reactions proceed by heterolytic fission are called ionic or polar reactions.

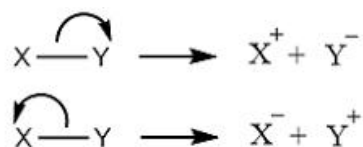





In a chemical reaction the molecule that transform into a different chemical species is called substrate (S). The new molecule formed is called as product (P). The attacking molecule used to effect this transformation is called reagent (R). Usually substrate and reagent are collectively called reactants.

A reagent is a chemical species that attacks the substrate in a chemical reaction to form a product. In a reaction it is used in lesser amount compared to product. Depending on the site of attack on the substrate, two types of reagents are recognized.

Nucleophile : (Nucleophilic reagent) :

An electron rich species which attacks an area of low electron density (positive centre) in the substrate is called nucleophile meaning nucleus loving. They donate a lone pair of electron to an acceptor to form a covalent bond and act as Lewis base.

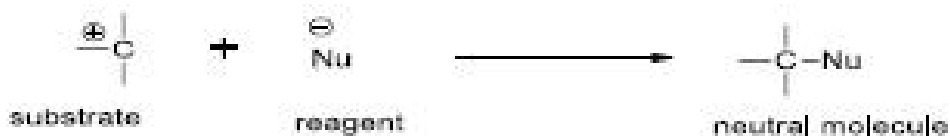

They can be of two types

➤ Negative or anionic nucleophiles:

Any negatively charged ion that carries a lone pair of electrons on its central atom acts as nucleophile and it is represented as (Nu<sup>-</sup>). They attack positively charged substrate or electron deficient point in neutral molecules.

e.g. -OH<sup>-</sup>, CN<sup>-</sup>, Cl<sup>-</sup>, I<sup>-</sup>, NH<sub>2</sub><sup>-</sup>, RCOO<sup>-</sup> etc.

➤ Neutral nucleophiles :

Any neutral molecule having a lone pair of electrons on its central atom acts as Nucleophile and represented as Nu. They attack on positively charged substrate to form positively charged species. e.g. H<sub>2</sub>O, ROH, RNH<sub>2</sub>, NH<sub>3</sub>, RSH

The reaction involving nucleophilic attack is called as nucleophilic reactions.

Electrophiles (electrophilic reagents) :

An electron deficient species which attacks the electron rich center on substrate is called as an electrophile meaning electron loving and denoted as (E). It acts as Lewis acid by accepting a pair of electrons from donor to form covalent bond.

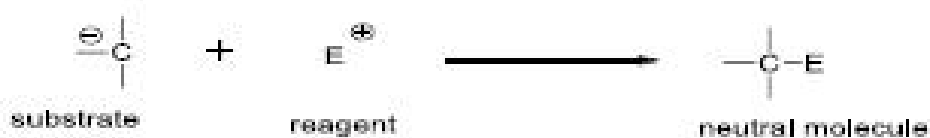

They can be of two types

➤ Positive or Cationic electrophiles :

Any positively charged ion acts as positive electrophile and represented as (E<sup>+</sup>). It attacks on electron rich centre on substrate forming a neutral molecule.

e.g.: H<sup>+</sup>, Br<sup>+</sup>, Cl<sup>+</sup>, NO<sub>2</sub><sup>+</sup>, NH<sub>4</sub><sup>+</sup>, H<sub>3</sub>O<sup>+</sup>, R<sub>3</sub>C<sup>+</sup>, Ar-N<sub>2</sub><sup>+</sup> etc.

➤ Neutral electrophiles (E):

Any neutral molecule whose central atom has incomplete octet acts as (E). neutral electrophile and represented as (E). They attack on positively charged substrate to form negatively charged species. The reactions involving electrophilic attack are called as electrophilic reactions.

e.g.: BF<sub>3</sub>, AlCl<sub>3</sub>, ZnCl<sub>2</sub>, FeCl<sub>3</sub> etc.

Free radicals (free radical reagents)

Groups which have unpaired valence electron are called free radicals. Free radicals are very reactive than electrophilic reagents and nucleophilic reagents. Free radicals are formed at the time reaction occurs.

e.g.: CH<sub>3</sub>·, OH·, CH<sub>3</sub>CH<sub>2</sub>·, Cl·

## Carbonium ions (carbocations)

Carbocation is defined as a group of atoms which contain positively charged carbon having only six electrons. It is obtained by Heterolytic fission of a covalent bond involving carbon atom. It is denoted by putting a positive charge (+) against the symbol of group of atoms.

### Structure of carbocation

The carbon atom in carbocation is  $sp^2$  hybridized. The three  $sp^2$  hybrid orbitals form three  $\sigma$  bonds with hydrogen or other carbon atoms of alkyl groups. The unhybridised  $p$ -orbital of carbon remains vacant. Since it involves  $sp^2$  hybridization, its structure is planar with a bond angle of  $120^\circ$ .

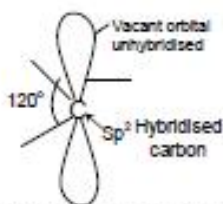

Planar structure of carbocation

|  |                         |                           |
|--|-------------------------|---------------------------|
| Primary Carbocation                          | Secondary Carbocation   | Tertiary Carbocation      |
| Methyl carbonium ion,<br>Ethyl carbonium ion | Isopropyl carbonium ion | Tert. Butyl carbonium ion |
| $CH_3^+$ , $CH_3CH_2^+$                      | $(CH_3)_2CH^+$          | $(CH_3)_3C^+$             |

### Characteristics of carbocations

- The formation of carbocations can be done,
  - By heterolysis of halogen compounds
  - By protonation of alkenes or alcohols
  - By decomposition of Diazo compounds
- Carbocations are not electrically neutral.
- There are six electrons in the out most orbit of carbon of carbocation i.e., 2 electrons less than octet.
- A carbocation is diamagnetic in nature due to all paired electrons.
- Carbocations are charged electrophiles i.e., they react with nucleophilic reagents.
- The order of reactivity of carbocations is,  
Primary ( $1^\circ$ ) > Secondary ( $2^\circ$ ) > Tertiary ( $3^\circ$ )

## Types of carbocations:

Carbocations can be classified into the following types,

- Alkyl carbocations
- Vinyl carbocation
- Allyl carbocation
- Phenyl methyl carbocations
- Aromatic carbocations

### Alkyl carbocations

- i. When positive charge is present on the alkyl carbon, carbocation is known as alkyl carbocation.
- ii. Alkyl carbocation is of four types

|                       |                              |                         |
|-----------------------|------------------------------|-------------------------|
| Primary Carbocation   | Methyl carbocations          | $\text{CH}_3^+$         |
|                       | Primary alkyl carbocations   | $\text{RCH}_2^+$        |
| Secondary Carbocation | Secondary alkyl carbocations | $\text{R}_2\text{CH}^+$ |
| Tertiary Carbocation  | Tertiary alkyl carbocations  | $\text{R}_3\text{C}^+$  |
- iii. Stability of alkyl carbocations can be explained by Inductive effect and hyper conjugation.
- iv. According to these two effects the stability order is as follows:  
 $\text{R}_3\text{C}^+ > \text{R}_2\text{CH}^+ > \text{RCH}_2^+ > \text{CH}_3^+$
- v. If  $\alpha$ -atom with respect to carbocationic carbon has one or more than one lone pair of electrons then lone pair of electrons strongly stabilizes a carbocation due to the delocalization.
- vi. Alkoxy and amino groups are important substituents for such type of carbocations.
  - a.  $(\text{CH}_3)_2\text{NCH}_2^+$  is more stable than  $(\text{CH}_3)_3\text{C}^+$
  - b.  $\text{CH}_3\text{OCH}_2^+$  is more stable than  $(\text{CH}_3)_3\text{C}^+$

### Vinyl carbocation

- i. When positive charge is present on vinylic carbon then carbocation is known as vinyl carbocation,  $\text{CH}_2=\text{CH}^+$
- ii. This carbocation is the least stable because positive charge is present on the electronegative carbon.

### Allyl carbocation

- i. When positive charge is present on the allylic carbon of the allyl group, the carbocation is known as allyl carbocation  $\text{CH}_2=\text{CH}-\text{CH}_2^+$ .
- ii. Allyl carbocations are more stable than the alkyl carbocations due to the resonance and are stabilized by delocalization.
- iii. Allyl carbocations are of the following types,

|                       |                              |  |
|-----------------------|------------------------------|--|
| Primary Carbocation   | Allyl carbocation            | $\text{CH}_2=\text{CH}-\text{CH}_2^+$          |
| Secondary Carbocation | Secondary Allyl carbocations | $\text{CH}_2=\text{CH}-\text{CH}(\text{R})^+$  |
| Tertiary Carbocation  | Tertiary Allyl carbocations  | $\text{CH}_2=\text{CH}-\text{C}(\text{R}_2)^+$ |
- iv. Stability of primary, secondary and tertiary allyl carbocations can be compared by, inductive effect and hyperconjugation. Thus, tertiary is more stable than secondary which is more stable than primary allyl carbocation.

### Phenyl methyl carbocations

- i. When positive charge is present on benzyl carbon, carbocation is known as phenyl methyl carbocation.

|                       |                              |  |
|-----------------------|------------------------------|--|
| Primary Carbocation   | Benzyl carbocation (or)      |  |
|                       | Phenyl methyl carbocation    | $\text{C}_6\text{H}_5-\text{CH}_2^+$   |
| Secondary Carbocation | Diphenyl methyl carbocation  | $(\text{C}_6\text{H}_5)_2-\text{CH}^+$ |
| Tertiary Carbocation  | Triphenyl methyl carbocation | $(\text{C}_6\text{H}_5)_3-\text{C}^+$  |
- ii. Stability of phenyl methyl carbocations can be explained by resonance.  
 $(\text{C}_6\text{H}_5)_3-\text{C}^+ > (\text{C}_6\text{H}_5)_2-\text{CH}^+ > \text{C}_6\text{H}_5-\text{CH}_2^+$   
Since  $3^\circ$  Carbocation has 10 resonating structure where as  $2^\circ$  Carbocation has 7 resonating structure and  $1^\circ$  Carbocation has 4 resonating structure.
- iii. Phenyl methyl carbocations are more stable than allyl carbocations due to the number of resonating structures.

### Aromatic carbocations

- i. Cations in which positive charge is present on carbon of aromatic system is known as aromatic carbocation.
- ii. Aromatic carbocations are so stable that even their solid states are known. For example tropylium carbocation as tropylium bromide is a yellow solid. It fact

tropolium carbocation is about  $10^{11}$  times more stable than triphenyl methyl carbocation.

- iii. Cations obeying Huckel ( $4n+2$ ) rule are stable because they are aromatic and there is complete delocalization of positive charge.

#### Cyclopropyl methyl carbocations

- i. These carbocations are very stable carbocations. They are more stable than benzyl carbocations.
- ii. Stability of Cyclopropyl methyl carbocations increases with every Cyclopropyl group.
- iii. Thus additional Cyclopropyl group has cumulative additive effect on the stability.

*Note: More stable is a carbocation, the more easily it is formed.*

### Carbanions

A carbanion may be defined as a species containing a carbon atom carrying a negative charge. These are generated by the Heterolytic fission of covalent bond involving carbon atom in which the atom linked to carbon goes without the bonding electrons. It is denoted by putting a negative charge ( $-$ ) against the symbol of group of atoms.

The negatively charged carbon atom in carbanion is  $sp^3$  hybridized. Therefore, it has a pyramidal structure. Three of the four  $sp^3$  hybridized orbitals form 3  $\sigma$  bonds with hydrogen or carbon atom of the alkyl group. The fourth  $sp^3$  hybrid orbital contains the lone pair of electrons.

*Note: Geometry of allyl and benzyl carbanion is almost planar and hybridization is  $sp^2$ .*

*Methyl anion is isostructural (pyramidal) and isoelectronic (eight valency electrons) with ammonia.*

*The carbanions having three different bulky groups are not optically active. It is due to pyramidal structure of carbanion which is not rigid and shows a rapid equilibrium between following two enantiomeric pyramidal structures.*

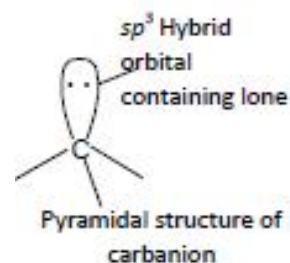

|  |                              |                             |
|--|------------------------------|-----------------------------|
| Primary Carbocation                          | Secondary Carbocation        | Tertiary Carbocation        |
| Methyl carbanion,<br>Ethyl carbanion         | Isopropyl carbanion          | Tert. Butyl carbanion       |
| $\text{CH}_3^-$ , $\text{CH}_3\text{CH}_2^-$ | $(\text{CH}_3)_2\text{CH}^-$ | $(\text{CH}_3)_3\text{C}^-$ |

### Characteristics of carbocations

- i. The formation of carbanions can be done,
  - By attack of base on hydrogen atom : Organic compounds which possess a labile or acidic hydrogen have the tendency to produce carbanions as in the case of reactive methylene compounds which lose proton in presence of sodium ethoxide ( $\text{C}_2\text{H}_5\text{ONa}$ ).
  - By the formation of organometallic compound;
- ii. Carbanions are not electrically neutral.
- iii. There are eight electrons in the outermost orbit of carbanionic carbon hence its octet is complete.
- iv. A carbanion is diamagnetic in nature due to all paired electrons.
- v. Carbanions are charged nucleophiles i.e., they react with electrophilic reagents.
- vi. The order of reactivity of carbanions is,  
Tertiary ( $3^\circ$ ) > Secondary ( $2^\circ$ ) > Primary ( $1^\circ$ )

### Stability of carbanions

- i. The stability of Aliphatic carbanion may be explained by
  - Electronegativity of carbanionic carbon
  - Inductive effect
  - Delocalization or Resonance
  - Stabilization by sulphur and phosphorous
  - Stabilization by  $>\text{C}=\text{O}$ ,  $-\text{NO}_2$  and CN groups present on carbanionic carbon
- ii. Stability of Aromatic carbanions
- I. The stability of Aliphatic carbanion may be explained by
  - a. Electronegativity of carbanionic carbon  
Stability  $\propto$  Electronegativity of carbanionic carbon  $\propto$  % s-character of carbanionic carbon

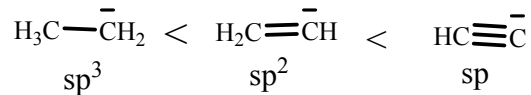

b. Inductive effect: Stability of carbanions depends on the +I or -I group as follows:

- ▲ Stability of carbanions inversely proportional +I power of the group
- ▲  $\text{R}_3\text{C}^- < \text{R}_2\text{CH}^- < \text{RCH}_2^- < \text{CH}_3^-$
- ▲ Stability of carbanions  $\propto$  -I power of the group
- ▲  $\text{I-CH}_2^- < \text{Br-CH}_2^- < \text{Cl-CH}_2^- < \text{F-CH}_2^-$

c. Delocalization or Resonance:

Allyl and benzyl carbanions are stabilized by delocalization of negative charge.

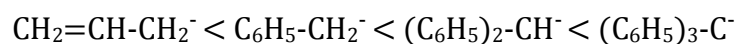

d. Stabilization by sulphur and phosphorous

Attachment of carbanionic carbon of a sulphur and phosphorus atom causes an increase in carbanion stability. The cause of stability is due to the delocalization of negative charge of carbanion by vacant d-orbital p-d bonding of phosphorus and sulphur.

e. Stabilization by  $>\text{C}=\text{O}$ ,  $-\text{NO}_2$  and  $\text{CN}$  groups present on carbanionic carbon

These groups stabilize carbanion by resonance effect.

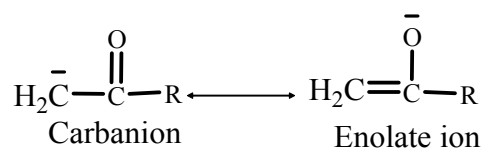

Contribution of structure (II) will be more than (I) because in (II) negative charge is present on electronegative oxygen.

## II. Stability of Aromatic carbanions

Anion in which negative charge is present on carbon of aromatic system is known as aromatic carbanions.

- ▲ Aromatic carbanions are most stable carbanions.
- ▲ Anions obeying Huckel rule are stable because they are aromatic and there is complete delocalization of negative charge. Eg Cyclopentadienyl anion



## Carbenes

A carbene may be defined as a species in which carbon atom has six electrons in the outer shell (electron deficient), out of which two constitute a lone pair and two are shared. So they are divalent carbon species containing two unpaired electrons and possess no charge. The simplest carbene is which known as methylene. Substituted carbenes are simply named as derivative of carbenes. For example,

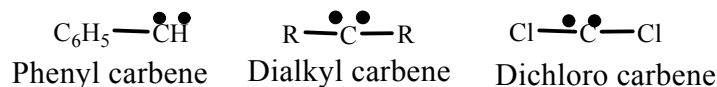

### Characteristics of carbnes

- i. Carbenes can be formed,
  - By the photochemical decomposition or pyrolysis of aliphatic diazo compounds or ketenes.
  - By the action of a base on suitable polyhalogen compound.
- ii. Carbenes are neutral, divalent, highly reactive carbon intermediates. They works as electrophiles

### Types and stability of carbenes

Carbenes are of two types

- i. Singlet: When both the electrons go into one orbital and have opposite spin (antiparallel), i.e., the unshared electrons are paired in one orbital and has a bent structure. The singlet state is actually found to have H-C-H bond angle  $103^\circ$  (between  $90^\circ$  to  $120^\circ$ ) and a C- H bond length of  $1.12\text{\AA}$ . It is generally considered as the less stable.
- ii. Triplet: When the two electrons go into different orbitals and have same spin (parallel), i.e., the unshared electrons are not paired. Such carbene would have a permanent magnetic moment and would exist in three closely grouped energy state, if it were placed in a magnetic field. Such a state is called triplet state and is believed to be a linear molecule. With H-C- H bond angle  $180^\circ$  and a C-H bond length of  $1.03\text{\AA}$ , it might be considered as a free diradical and is more stable.

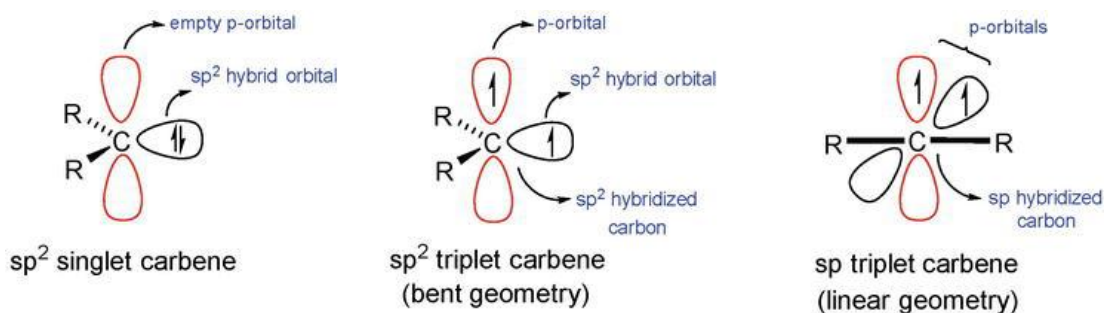

### Arynes

- i. 1, 2-Didehydrobenzene, C<sub>6</sub>H<sub>4</sub> and its derivatives are called benzyne or arynes and the simplest member is benzyne.
- ii. It is neutral reaction intermediate derived from benzene ring by removing two substituents, of ortho positions, one in the form of electrophile and other in the form of nucleophile leaving behind two electrons to be distributed between two orbitals.

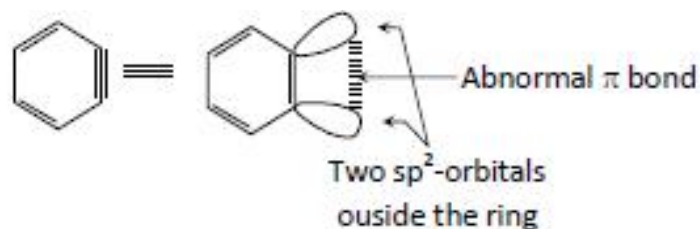

- iii. Benzyne intermediate is aromatic in character.
- iv. When halobenzene is heated with sodamide formation of benzyne takes place.

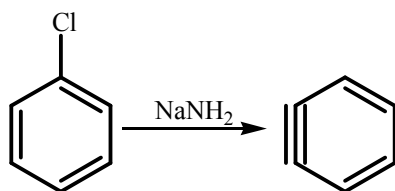

- v. It behaves as dienophile and gives Diels-Alder reaction with diene.
- vi. It reacts with strong nucleophile like NH<sub>2</sub><sup>-</sup>

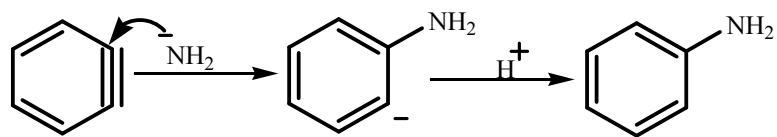

## Nitrenes

- The nitrogen analogous of carbenes are called nitrenes.

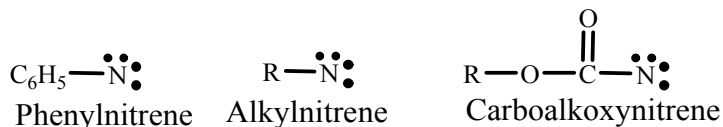

- There is possibility of two spin states for nitrenes depending on whether the two nonbonding electrons (the normal nitrogen lone pair remains paired) have their spins paired or parallel.

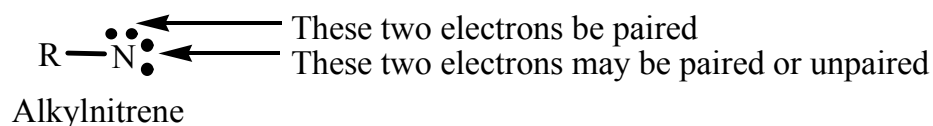

- In general nitrenes obey Hund's rule and are ground state triplet with two degenerate sp-orbitals containing a single electron each. It also exists in singlet state as sp<sup>2</sup> hybridized orbital. singlet state

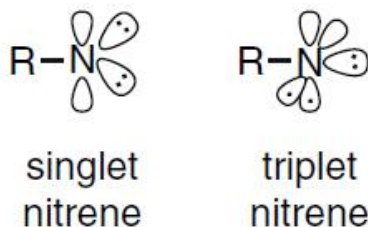

- The energy difference between singlet and triplet state is usually much larger for nitrenes than carbenes. The energy difference is due to electronegativity difference in carbon and nitrogen. Nitrogen is more electronegative than carbon so it holds its electron closer to the nucleus which decreases the energy and hence the stability increases. The nature of the substituent on nitrogen affects both the multiplicity and the normal electrophilic reactivity of nitrenes. Strong π donor substituents such as amino group greatly stabilize the singlet as well as causing the nitrene to exhibit the nucleophilic character in the reaction and stable at low temperature.
- Nitrenes can be generated, in situ, by the following methods,
  - ▲ By action of 2 Br in presence of a base on a 1o amide (Hofmann-bromamide reaction),

- ▲ By decomposition of azides in presence of heat or light.

### **ELECTRONIC EFFECTS**

Electronic effects are the effects originating or present in the organic molecules due to which the reactivity or property at one part of a molecule is affected by electron attraction or repulsion originating in another part of a molecule. The originating place of the electronic effect is where the substituents are connected to the molecule. If we consider hydrocarbons, they are non-polar. But the compound having functional groups i.e., having hetero atom (i.e., atoms other than carbon) or groups the molecule becomes polar. While studying all these effects, it is necessary to consider how the presence of a hetero atom/group introduces polarity in the organic molecules. It is in the context of this group which is known to exert different types of effects on the remaining part of the molecule.

There are three main electronic effects;

- ▲ Inductive effect
- ▲ Mesomeric (resonance) effect
- ▲ Hyperconjugation

#### **Inductive effect**

Inductive effects involve electrostatic effects transmitted through sigma bonds. Elections in C-C bonds are more readily polarized than those in a C-H bond. Ideally, a covalent bond between two atoms must share the pair of electrons equally. If the electronegativities of the two atoms are different, this sharing of electrons is not equal and the more electronegative atom gets a fractional negative charge due to the greater attraction of the shared pair of electrons towards itself and the other atom gets a fractional positive charge. Fractional or partial negative charge is represented by  $\delta^-$  (pronounced as delta minus) and Fractional or partial positive charge is represented by  $\delta^+$  (pronounced as delta plus),  $\delta$  signifying the very less magnitude of charge

Inductive effect has the following characteristics:

- ▲ It is a permanent effect.
- ▲ It operates through sigma bonds. (Note that all the single, double and triple bonds have a sigma bond in them.)

- ▲ Its magnitude goes on decreasing with increase in distance from the atom/group responsible for the same. Inductive effect is almost negligible after the third or fourth atom

Induction or the inductive effect of an atom or a group is a function of that group's following parameter:

- ▲ Stability of carbocations (carbonium ions)
- ▲ Electronegativity
- ▲ Bonding order and charge
- ▲ Position within a structure

For example, C - X (X = halogen) bond is polar with C having a  $\delta+$  charge and the halogen having a  $\delta-$  charge. The magnitude or value of these fractional charges increases with an increase in the electronegativity of the halogen i.e., for halogens, it is in the order  $F > Cl > Br > I$ .

Let us consider a carbon chain, with the end carbon joined to a more electronegative atom say Cl, then Cl will attract electrons ( $\sigma$  electrons between C and Cl) more towards itself. Hence, the carbon atom will become slightly electron deficient and get a fractional positive charge ( $\delta+$ ) due to a difference of electronegativity.

This polarization is not restricted for that carbon, but it induces polarity further in the chain and hence it names as the inductive effect.

**Consider the following example of 1- chlorobutane;**

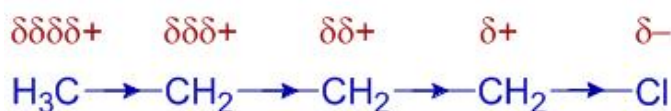

Consider the following example of 1- chlorobutane;

Here, first C acquires slight positive charge ( $\delta+$ ) due to the electronegativity of Cl which in turn acquires slight negative charge ( $\delta-$ ). Then that C thus becomes electron deficient and it exerts a pull on the electrons forming covalent bond between first C and second C but less strongly. As a result, second C acquires a lesser positive charge ( $\delta\delta+$ ) as that on first C. The third C similarly acquires even lesser positive charge ( $\delta\delta\delta+$ ) and so on. Thus, a polarity is slowly induced throughout the carbon chain. The effect get weaken when carbon get away from electronegative atom. However, the effect is very less beyond carbon

3 or 4. In other words, the effect diminishes as one moves further in the carbon chain relative to the position of the group.

The phenomenon of transmission of charge arising due to electronegativity difference in a covalent bond (i.e., dipole) through a chain of carbon atoms linked by sigma bonds is called inductive effect.

The Inductive effect is related to the ability of Substituent(s) to either withdraw or donate electron density to the attached carbon atom. Based on the ability, the substituents can be classified as electron donating groups or electron withdrawing groups relative to Hydrogen.

Some examples to electron -releasing/ donating groups:

▲  $-\text{CH}_3$  (Methyl),  $-\text{CH}_2\text{-CH}_3$  (Ethyl Group) etc.

Some examples to electron -withdrawing groups:

▲  $-\text{X}$ ,  $-\text{NO}_2$  (Nitro Group),  $-\text{CN}$  (Cyano Group),

▲  $-\text{COOH}$  (Carboxy Group),  $-\text{COOR}$  (Ester Group),

▲  $-\text{OAr}$  (Aryloxy Group) etc.

If the substituent "X" bonded to Carbon atom is ELECTRON WITHDRAWING then C atom acquires positive (+) charge and such Inductive effect is termed as -I Effect.



In the chlorobutane, group Cl attracting electrons towards itself is normal due to the difference of electronegativity but induction of polarity in an otherwise non-polar bond due to the attachment of a more electronegative atom. The atoms/groups like Cl which are more electronegative than carbon gain a slight negative charge on them and withdraw the electrons of the carbon chain towards themselves are known to exert -I Effect (pronounced as "minus I effect")

Following order of the strength of -I effect exerted by electronegative groups attached to the chain

$-\text{NO}_2 > -\text{CN} > -\text{COOH} > \text{F} > \text{Cl} > \text{Br} > \text{I} > \text{OH} > \text{C}_6\text{H}_5 > \text{H}$

If the substituent "Y" bonded to Carbon atom is ELECTRON RELEASING then Y atom acquires positive (+) charge and such Inductive effect is termed as +I Effect (pronounced as "plus I effect")

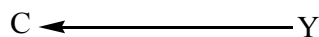

Though the C-H bond is practically considered as non-polar, there is partial positive charge on hydrogen atom and partial negative charge on carbon atom. Therefore, each hydrogen atom acts as electron donating group. This cumulative donation turns the alkyl moiety into an electron donating group.

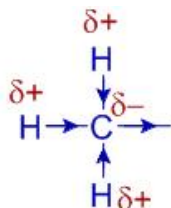

There are very few atoms or groups forming compounds with carbon which are more electropositive than carbon e.g. H. However, the most important group exhibiting +I effect is the alkyl group, which due to a difference in electronegativities of hydrogen and carbon, makes the carbon slightly electron rich. Then, alkyl group is to possess +I effect.

+I Effect: Here, due to the electropositivity of the first atom, the electrons are pushed away from itself. The further attached atoms or groups shall enhance the +I if they also push by +I effect, but will decrease the +I effect if they are electron withdrawing by -I effect

For example, the order of +I effect between the following groups is

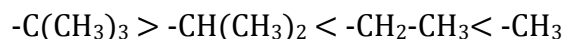

### Stability of carbocations (carbonium ions)

The stability of carbocations increase when +I groups like alkyl groups are present adjacent to positively charged carbon. The +I groups reduce the positive charge on the carbon by donating negative charge density through positive inductive effect. This results in greater stability of carbocation. Whereas, the -I groups destabilize the carbocations as they increase the positive charge by withdrawing electron density.

For example, the order of stability of a few carbocations containing alkyl groups is as follows:

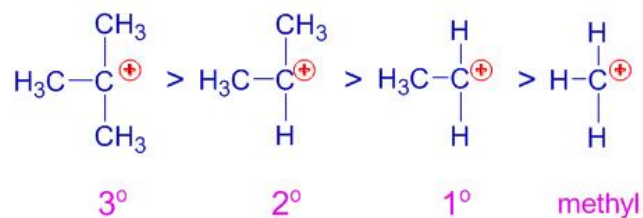

### Electronegativity

Due to the -I effect, these electronegative atoms withdraw electron density through the single bond and can assist in the stabilization of negative charge that may form in reactions like carbanions, oxygen anions etc. On the contrary, they shall destabilise the positively charged species like carbocations and electron deficient species like free radicals.

-I groups have a stabilizing (enhancing) effect on the ionization of acids. For example,, trichloroacetic acid is the strongest acid. This is due to the fact that greater are the number of Cl atoms, greater is the -I effect and hence greater ionisation as well as stability of conjugate anion.

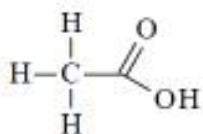

Acetic acid  
pKa = 4.76

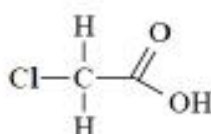

Chloroacetic acid  
pKa = 2.87

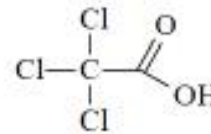

Trichloroacetic acid  
pKa = 0.64

Atoms or functional groups that are electron donating (hydrocarbons, anions) have a positive inductive effect (+I). These groups can help stabilize positive charges in reactions such as protonation of bases. On the contrary they shall destabilise the anions.

### Bonding order and charge

It is important to consider both the electronegativity and bonding order when analysing the inductive potential of an atom.

As a rule, negatively charged group shall be electron repelling and hence +I. On the other hand, positively charged group shall be electron attracting and hence -I.

For example, oxygen in a hydroxyl group (OH) is electron withdrawing by -I effect because the oxygen atom is relatively electronegative and is uncharged in that bonding arrangement. On the other hand, oxygen in an "alkoxide ion"(O-) is electron donating by +



I effect because in this bonding order (a single bond to oxygen) it has an "excess" of electron density.

Similarly,  $-\text{NH}_2$  is a  $-I$  effect group;  $-\text{NH}^-$  is a  $+I$  effect group and  $-\text{NH}_3^+$  is a  $-I$  effect group.

### Bonding position

The strength of the inductive effect diminishes as we move farther away from the group. The I effect produced by a particular atom or functional group is dependent on its position within a structure.

For example, out of the following acids, (I) is more acidic than (II). This is because the Cl atom is closer to the  $-\text{COOH}$  group in (I) than it is in (II)



Inductive effect is useful in describing many phenomena in organic molecules

- ▲ Polarization
- ▲ Changing in bond lengths
- ▲ Boiling points/ melting points
- ▲ Solubility
- ▲ Acidity
- ▲ Magnitude of acidity
- ▲ Basicity and magnitude of basicity
- ▲ Reactivity
- ▲ Stabilization / destabilization of reactive intermediates

Inductive effect is useful in explaining the strength of some organic acids and bases.

- i. Effect of substituent on the acid strength of aliphatic acids.



Reason: Acidic strength decreases as  $+I$  effect of the alkyl group increases.

- ii. Effect of substituent on the acid strength following acids.



Reason: Acidic strength decreases as -I effect of the group or halogen decreases.

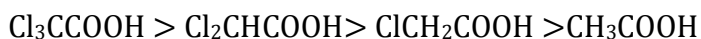

Reason: Acidic strength decreases as the number of halogen atoms decreases.

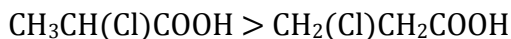

Reason: Acidic strength decreases as the distance of the halogen from carboxylic group increases.

iii. All aliphatic amines are more basic than ammonia.

Methyl amine is more basic than ammonia.

Reason: Due to +I effect of methyl group.

Aniline is weaker base than Ammonia.

Reason: Due to +R effect and -I Effect of phenyl group.

iv. Bond length of alkyl halides

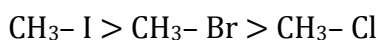

Reason: Bond length decreases when -I effect increases

### Mesomeric Effect / Resonance Effect

Mesomeric Effect /Resonance effects involve transmission of electron density through the p system of molecules. The flow of electrons from one part of a conjugated p system to the other caused by phenomenon of resonance is called resonance effect or mesomeric effect.

The effect is used in a qualitative way and describes the electron withdrawing or releasing properties of substituents based on relevant resonance structures. The polarity developed between atoms of a conjugated system by pi-bond electron transfer. In other words, mesomeric effect (M)/ resonance effect is a delocalization of p orbitals. Mesomeric effect can be transmitted along any number of carbon atoms in a conjugated system. This accounts for the resonance stabilization of the molecule due to delocalization of charge.

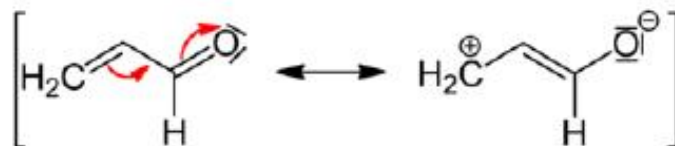

Example; Stabilization of amide ion by resonance effect

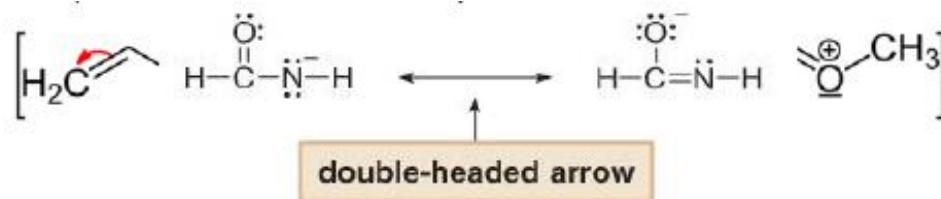

### Conjugative system

The delocalization / resonance mainly arises when there is following conjugation in the molecules/ions

- $\pi$  bond -  $\pi$  bond
- $\pi$  -electrons -orbital with lone pair,
- $\pi$  -electrons-orbital with radical
- $\pi$  electrons -orbital with ions

### Stabilization of allylic carbocation by resonance effect

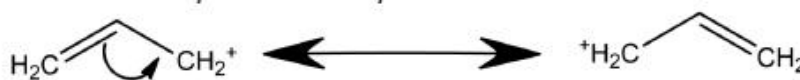

The above resonance effect in a molecules /ion produce resonance structures. When more resonance structures mean, more delocalization., and more stability

### Resonance structures

If two or more than two different structures can be drawn for a molecule or ion that are having the same arrangement of atomic nuclei but differ in the distribution of electrons, this effect can be termed as the resonance effect. The different structures are called contributing or resonating structures. Not all the properties of the molecule or ion are shown by the single resonating structure but the actual structure is a resonance hybrid of all the resonating structures.

### Resonance energy

When more resonance structures are formed, the actual structure is the resonance hybrid. which is more stable than individual structures?

The energy of actual structure of the molecule (the resonance hybrid) is lower than that of any of the canonical structures. The difference in energy between the actual structure and the lowest energy resonance structure is called the resonance stabilization energy or

simply the resonance energy. The more the number of important contributes structures, the more is the resonance energy.

Example: Benzene has two resonance structures and the real structure is the resonance hybrid.

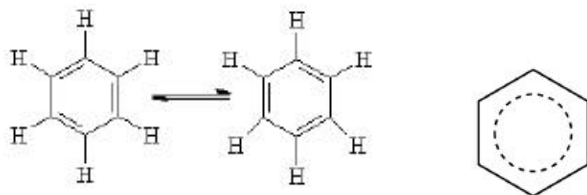

The energy of individual resonance contributors is higher than that of hybrid. This energy difference is called as “resonance energy” which is the stabilization energy.

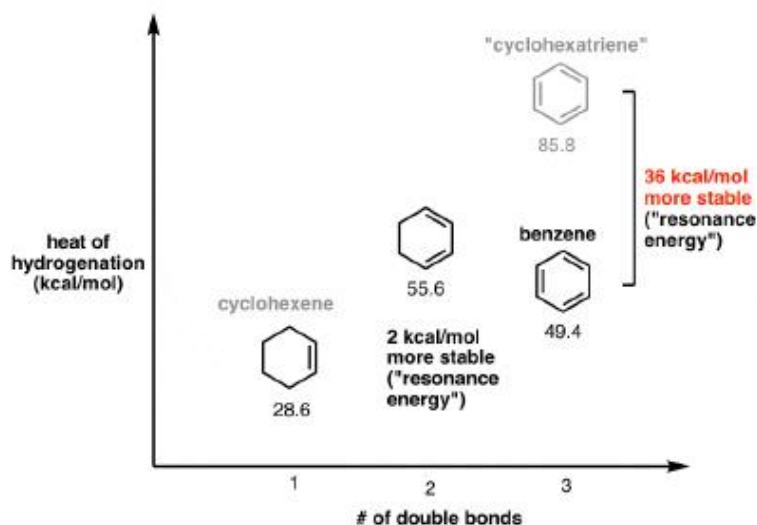

### Positive Resonance Effect (+R effect)

The effect is positive (+M) when the substituent is an electron releasing group. In this effect, the transfer of electrons is away from an atom or substituent group attached to the conjugated system. This electron displacement makes certain positions in the molecule of high electron densities

Example-1

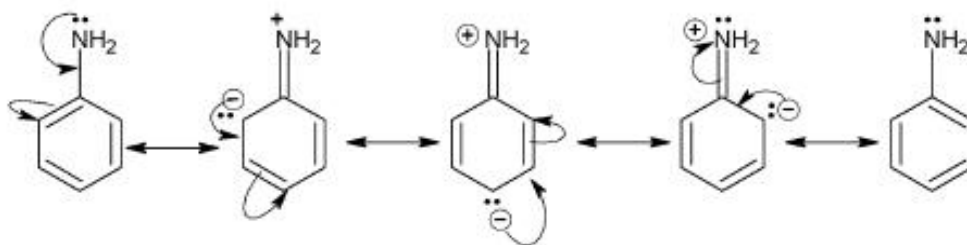

For the +M effect, the group should have either a lone pair of electrons or should have a negative charge.

The +M effect gives negative charge to the conjugate system or it can be said that the electron density increases on the conjugate system due to this. These conjugate systems show more reactivity towards electrophiles and less reactivity towards a nucleophile.

Example-2

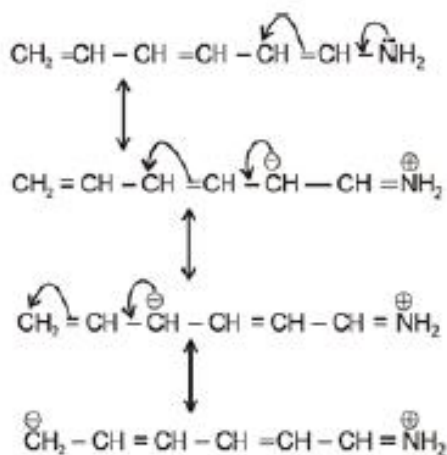

*Group showing +M effect*

-NH, -NH<sub>2</sub>, -NHR, -NR<sub>2</sub>, -O, -OH, -OR, -F, -Cl, -O-COR, -NHCOR, -SH, -SR etc.

+M effect order:

-O- > -NH<sub>2</sub> > -NHR > -OR > -NHCOR > -OCOR > -Ph > CH<sub>3</sub> > -F > -Cl > -Br > -I

Positive mesomeric effect explain why carboxylic acid is acidic. The stability of resultant is stabilized by positive (+) mesomeric effect.

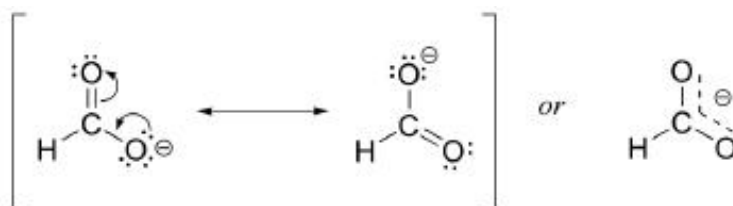

### Negative Resonance Effect (- R effect)

When the pi-bond electrons are transferred from the conjugate system to a particular group thus the electron density of the conjugate system is decreased, then this phenomenon is known as negative mesomeric (-M) effect.

The mesomeric effect is negative (-M) when the substituent is an electron-withdrawing group

#### Example-1

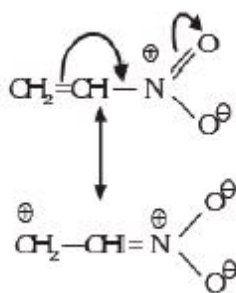

#### Example-2

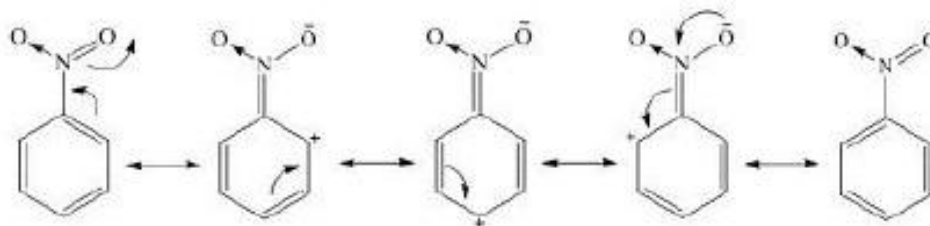

For -M effect, the group should have either a positive charge or should have a vacant orbital.

-M effect makes the compound more reactive towards a nucleophile as it decreases the electron density in the conjugate system and at the same time it is less reactive towards electrophile due to same reasons.

*The group which shows -M effect include;*

-NO<sub>2</sub>, -CN, -COX, -SO<sub>3</sub>H, -CHO, -CONH<sub>2</sub>, -COR, -COOH, -COOR etc

-M effect order:

-NO<sub>2</sub> > -CN > -S(=O)<sub>2</sub>-OH > -CHO > -C=O > -COOCOR > -COOR > -COOH > -CONH<sub>2</sub> > -COO-

Application of mesomeric effect

**Carbocation Stability** Carbocation's stability is enhanced by resonance. All the aromatic compounds are always more stable as compared to non-aromatic compound due to the effect of resonance.



**Carboanion Stability** Carbanion's stability is increased by resonance.



**Stability of free radicals** Resonance increases the stability of free radicals.

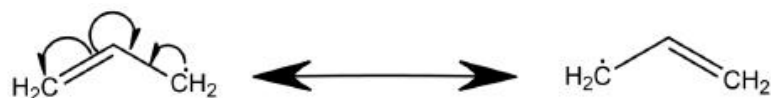

**Acidity of carboxylic acid / Phenol**

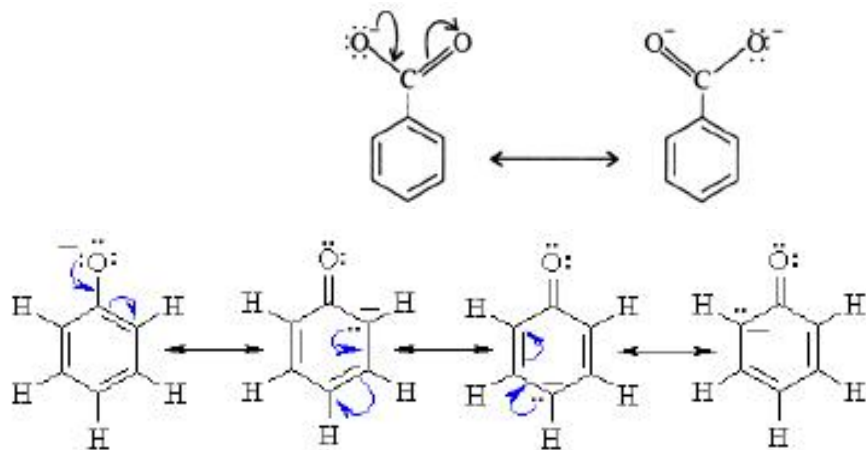

**Basicity strength**

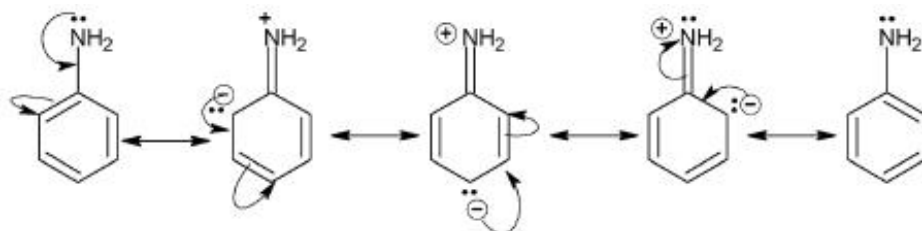

### Electromeric effect

Electromeric Effect can be observed only in organic compounds which contain multiple bonds. It is a temporary effect that arises when the compound is subjected to an attacking reagent.

The instantaneous formation of a dipole in the molecule of an organic compound due to the complete transfer of shared pi electron pairs to one of the atoms under the influence of an attacking reagent is referred to as the Electromeric effect.

This effect can be observed in organic compounds that contain at least one multiple bond. When the atoms participating in this multiple bond come under the influence of an attacking reagent, one pi bonding pair of electrons is completely transferred to one of the two atoms.

The electromeric effect is a temporary effect that remains as long as the attacking reagent is present and exposed to the organic compound. Once this attacking reagent is removed from the system, the molecule that was polarized goes back to its original state.

#### Types of electromeric effect:

The electromeric effect can be broken down into two types, namely the +E effect and the -E effect. This classification is done based on the direction in which the electron pair is transferred.

##### ➤ +E Effect:

This effect occurs when the electron pair of the pi bond is moved towards the attacking reagent. The +E effect can be observed in the addition of acid to alkenes. The attacking reagent attaches itself to the atom which obtained an electron pair in the transfer. The +E effect is generally observed when the attacking reagent is an electrophile and the pi electrons are transferred towards the positively charged atom. An example where the +E effect occurs is the protonation of ethene which is illustrated below.

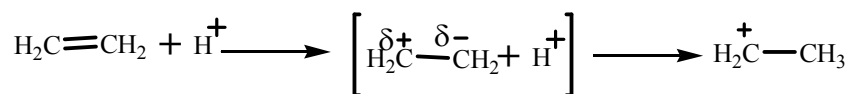

##### ➤ -E Effect:

This effect occurs when the electron pair of the pi bond is moved away from the attacking reagent. The attacking reagent attaches itself to the positively charged atom in the molecule, i.e. the atom which lost the electron pair in the transfer. The -E effect is generally observed when the attacking reagent is a nucleophile and the pi electrons are transferred to the atom which the attacking reagent will not bond with.



An example where the -E effect occurs would be the addition of nucleophiles to carbonyl compounds as illustrated below.

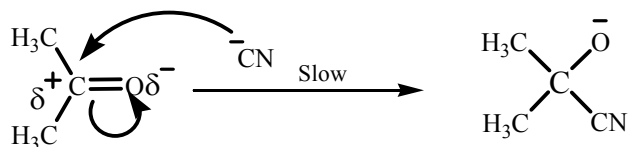

### Hyperconjugation

Baker and Nathan suggested that alkyl groups with at least one  $\alpha$ -hydrogen atom, when attached to an unsaturated carbon atom, are capable to release electrons by a mechanism similar to that of the electromeric effect. This effect is known as hyperconjugation or Baker-Nathan effect. Hyperconjugation is an unusual type of resonance in which delocalization of electrons takes place through the overlapping between the sigma ( $\sigma$ ) bond orbital (usually C-H or C-C) with an adjacent empty or partially filled p-orbital or a  $\pi$ -orbital giving an extended molecular orbital that increases the stability of the system. The stabilization arises because the orbital interaction leads to the electrons being in a lower energy orbital (Figure a). Hyperconjugation occurs due to the partial overlap of  $sp^3$ -s  $\sigma$  bond orbital and the empty p-orbital or  $\pi$ -bond orbital of an adjacent carbon atom.

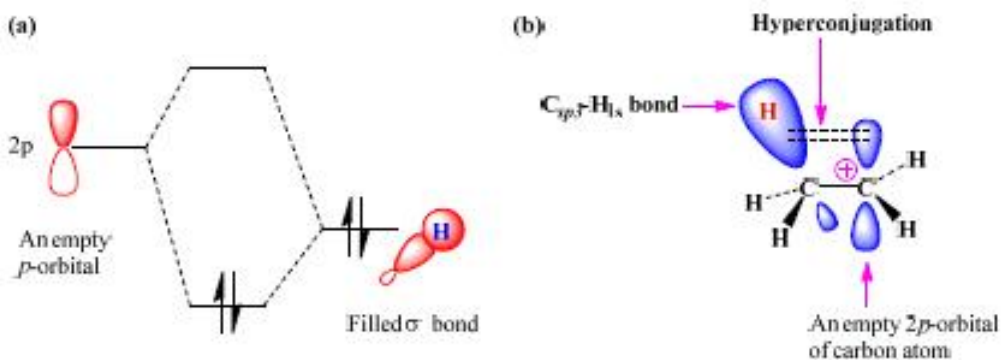

### The orbital pictures of hyperconjugation

From figure b, we observe that one of the three C-H bonds of the methyl group can align in the plane of the empty p-orbital and the electrons constituting the C-H bond in a plane with this p-orbital can then be delocalized into the empty p-orbital. This results in the delocalization of  $\pi$ -electrons and increases the stability of molecule.

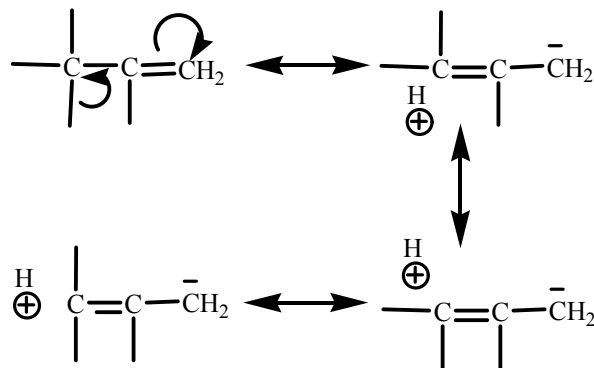

In the resonating structures of propene, there is no bond between carbon and hydrogen ions, therefore, hyperconjugation is also called as no bond resonance.

Based on the valence bond model of bonding, hyperconjugation can be described as “double bond-no bond resonance”. This type of delocalization involves  $\sigma$  and  $\pi$ -orbitals, and thus it is also called as  $\sigma$ - $\pi$  conjugation. Notably, Hyperconjugation effect is a permanent effect.

#### *Examples of Hyperconjugation*

- i. Carbonium ion: In carbocation or carbonium ion such as ethyl carbocation, the  $\sigma$  electrons of  $C_{sp^3}$ -hydrogen bond are delocalized with an empty p-orbital of positively-charged carbon atom and can show four contributing structures, similar to that of propene as discussed above.

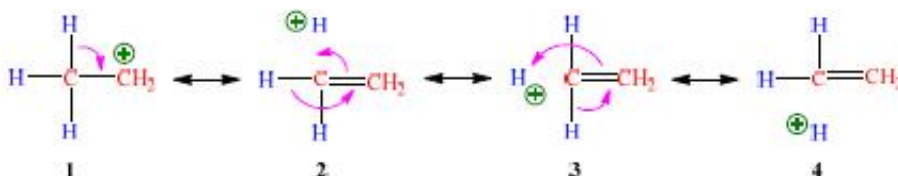

- ii. Free radicals: Like carbonium ion, free radicals get stabilized through hyperconjugation. The  $\sigma$  electrons of C-H bonds of methyl group next to the carbon atom contain an odd electron and interact with p-orbital having an odd electron. As the number of  $\alpha$  carbon hydrogen bond increases, the number of contributing structures also increases resulting in greater stability.
- iii. Alkene: In 2-butene, the interaction of  $\pi$ -bond with  $\alpha$ -carbon-hydrogen bond can form six resonating structures of 2-butene
- iv. Nitromethane: The nitrogen-oxygen  $\pi$ -bond can interact with  $\alpha$ -carbon-hydrogen bond as shown below.

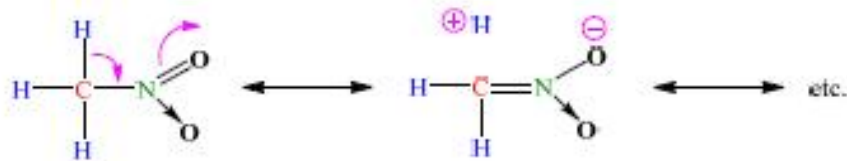

- v. The carbon-hydrogen  $\sigma$  bond interacts with  $\pi$ -bond of aromatic ring to form four contributing structures of toluene.

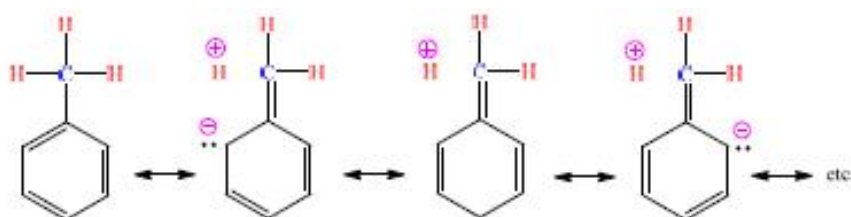

### Applications of hyperconjugation effect

#### Stability of alkenes and other unsaturated hydrocarbons:

The stability of alkenes increases with increase in the number of alkyl groups (containing hydrogens) on the double bond. It is due to increase in the number of contributing no bond resonance structures.

For example, 2-butene is more stable than 1-butene. This is because in 2-butene, there are six hydrogens involved in hyperconjugation whereas there are only two hydrogens involved in case of 1-butene. Hence the contributing structures in 2-butene are more and is more stable than 1-butene.

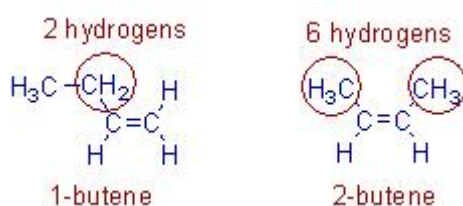

The increasing order of stability of alkenes with increases in the number of methyl groups on the double bond is depicted below.

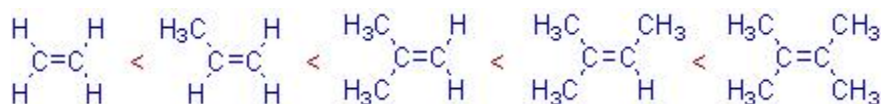

This order is supported by the heat of hydrogenation data of these alkenes. The values of heats of hydrogenation decrease with increase in the stability of alkenes.

Also the heats of formation of more substituted alkenes are higher than expected.

However it is important to note that the alkyl groups attached to the double bond must contain at least one hydrogen atom for hyperconjugation. For example, in case of the following alkene containing a tert-butyl group on doubly bonded carbon, the hyperconjugation is not possible.

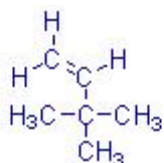

No H atoms on  $\alpha$  carbon.  
Hence no hyperconjugation.

It is also important to note that the effect of hyperconjugation is stronger than the inductive effect.

For example, the positive inductive effect of ethyl group is stronger than that of methyl group. Hence based on inductive effect, 1-butene is expected to be more stable than propene. However propene is more stable than 1-butene. This is because there are three hydrogens on  $\alpha$ -methyl group involved in hyperconjugation. Whereas, in 1-butene there are only two hydrogen atoms on  $-\text{CH}_2$  group that can take part in hyperconjugation.

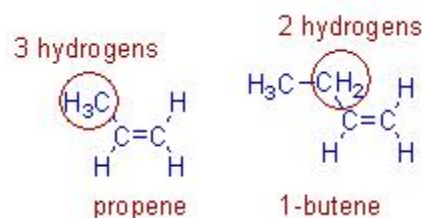

#### Stability of carbocations (carbonium ions):

The ethyl carbocation,  $\text{CH}_3\text{-CH}_2^+$  is more stable than the methyl carbocation,  $\text{CH}_3^+$ . This is because, the  $\sigma$ -electrons of the  $\alpha$ -C-H bond in ethyl group are delocalized into the empty p-orbital of the positive carbon center and thus by giving rise to 'no bond resonance structures' as shown below. Whereas hyperconjugation is not possible in methyl carbocation and hence is less stable.

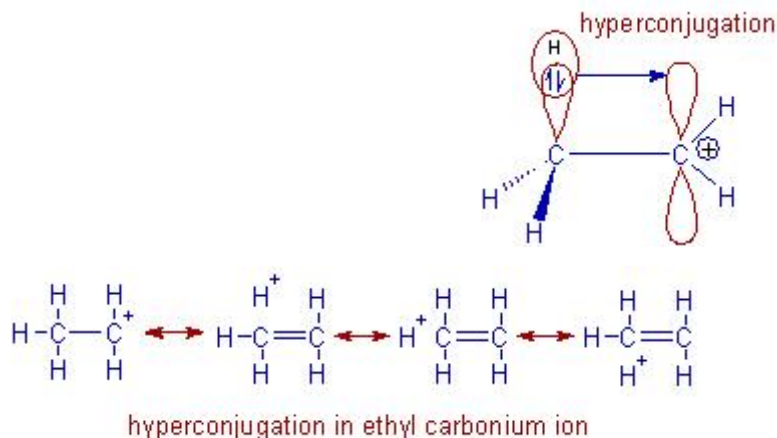

In general, the stability of carbonium ions increases with increase in the number of alkyl groups (containing hydrogen) attached to the positively charged carbon due to increase in the number of contributing structures to hyperconjugation.

*Note: This type of hyperconjugation can also refer to as isovalent hyperconjugation since there is no decrease in the number bonds in the no bond resonance forms.*

Thus the increasing order of stability of carbocations can be given as: methyl < primary < secondary < tertiary as depicted below:

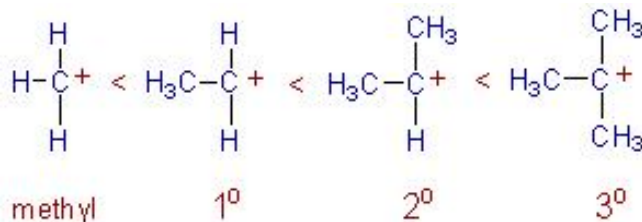

### Stability of free radicals:

The stability of free radicals is influenced by hyperconjugation as in case of carbonium ions. The the  $\sigma$ -electrons of the  $\alpha$ -C-H bond can be delocalized into the p-orbital of carbon containing an odd electron.

Due to hyperconjugation, the stability of free radicals also follow the same order as that of carbonium ions i.e., methyl < primary < secondary < tertiary.

### Dipole moment & bond length:

The dipole moment of the molecules is greatly affected due to hyperconjugation since the contributing structures show considerable polarity.

The bond lengths are also altered due to change in the bond order during hyperconjugation. The single bond may get partial double bond character and vice versa.

E.g. The observed dipole moment of nitro methane is greater than the calculated value due to hyperconjugation. The observed C -N bond length is also less than the expected value due to same reason.

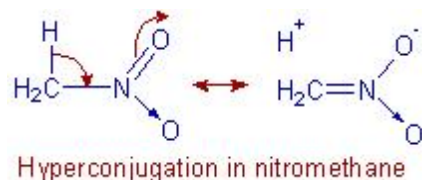

Hyperconjugation influences the dipole moment in the molecule because it impacts the formation of charges.

Acetaldehyde ( $\mu = 2.72D$ ), the dipole moment increases, leading to hyperconjugation and the production of charges where the hydrogen of formaldehyde ( $\mu = 2.3D$ )

The same arguments can be applied to shortening of C-C bond adjacent to  $-C\equiv N$  in acetonitrile and also the C-C bond adjacent to the  $-C\equiv C$  in propyne. Also note that the observed dipole moments are again different from their expected values.

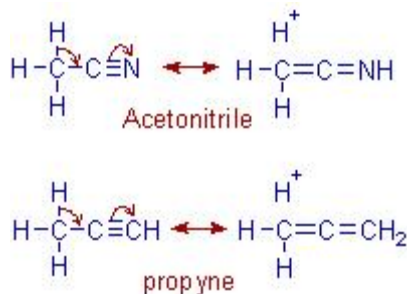

### Reactivity & orientation of electrophilic substitution on benzene ring :

In Toluene, the methyl group releases electrons towards the benzene ring partly due to inductive effect and mainly due to hyperconjugation. Thus the reactivity of the ring towards electrophilic substitution increases and the substitution is directed at ortho and para positions to the methyl group.

The no bond resonance forms of toluene due to hyperconjugation are shown below.

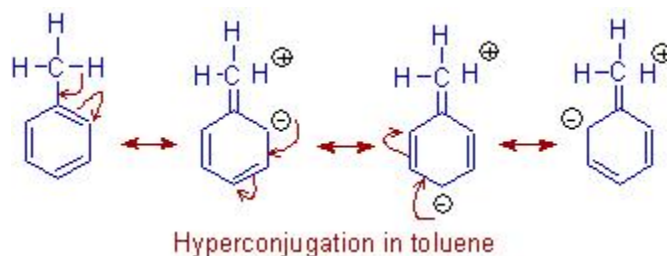

From the above diagram, it can be seen clearly that the electron density on benzene ring is increased especially at ortho and para positions.

Since the hyperconjugation overpowers the inductive effect, the substitution (e.g. nitration) on the following disubstituted benzene occurs ortho to the methyl group. In the tert-butyl group, there are no hydrogens on the carbon directly attached to the benzene ring. Hence it cannot involve in hyperconjugation.

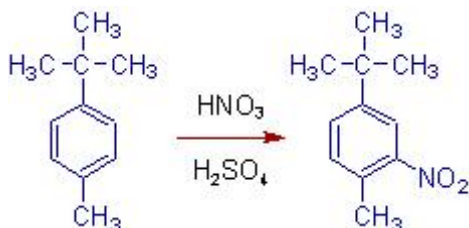

Also note that the tert-butyl group is bulky and hinders the approach of electrophile.

#### Anomeric effect :

The general tendency of anomeric substituents to prefer an axial position is called Anomeric effect.

For example, the  $\alpha$ -methyl glucoside is more stable than the  $\beta$ -methyl glucoside due to hyperconjugation.

In  $\alpha$ -methyl glucoside, the non bonding HOMO with a pair of electrons on the ring oxygen is antiperiplanar to the antibonding LUMO of C-O bond in methoxy group. This allows hyperconjugation between them and thus by stabilizing the  $\alpha$ -form.

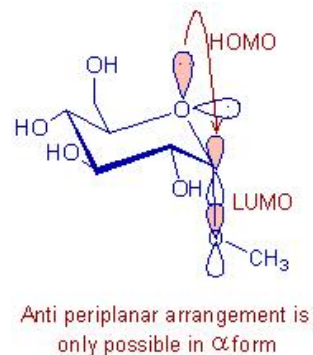
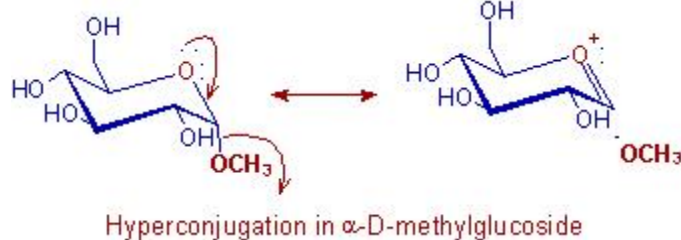

Whereas, in  $\beta$ -methyl glucoside the methoxy group is at equatorial position and cannot involve in hyperconjugation since it is not antiperiplanar to the lone pair on ring oxygen. Therefore  $\beta$ -methyl glucoside is less stable than the  $\alpha$ -methyl glucoside.

#### Reverse hyperconjugation:

In case of  $\alpha$ -halo alkenes, the delocalization of electrons occurs towards halogen group through hyperconjugative mechanism. It is referred to as reverse hyperconjugation. The dipole moments of  $\alpha$ -halo alkenes are augmented due to this phenomenon.

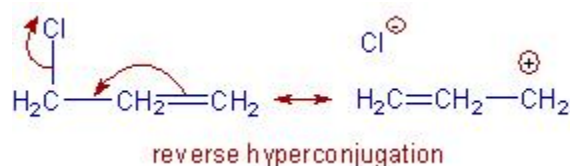

### TYPES OF ORGANIC REACTIONS

There are four different types of organic reactions that can occur. Let us understand them.

#### Substitution Reactions

In a substitution reaction, one atom or a group of atoms is replaced by another atom or group of atoms, resulting in the formation of a completely new chemical compound.

Example:

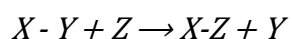

In the above reaction Y is substituted by Z. Such kinds of reactions in organic chemistry are said to be substitution reactions.

Substitution reactions are of two types:

#### ***Nucleophilic substitution reaction***



If a substitution reaction is brought about by a nucleophile, then it is known as a nucleophilic substitution reaction. The general reaction represents the nucleophilic substitution reaction.

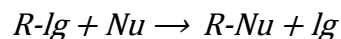

Where Nu is Nucleophile and lg is the leaving group.

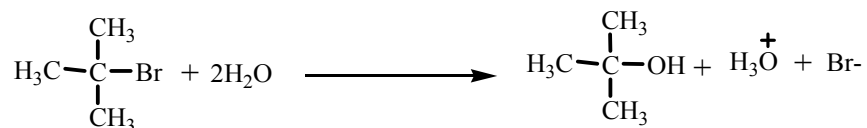

Nucleophilic substitution reactions can be further classified into three types:

(I) S<sub>N</sub>1 reaction:

The S<sub>N</sub>1 reaction is a unimolecular nucleophilic substitution reaction.

The S<sub>N</sub>1 reaction mechanism follows a step-by-step process wherein first, the carbocation is formed by the removal of the leaving group. Then the carbocation is being attacked by the nucleophile. Finally, the deprotonation of the protonated nucleophile takes place to give the required product.

Example:

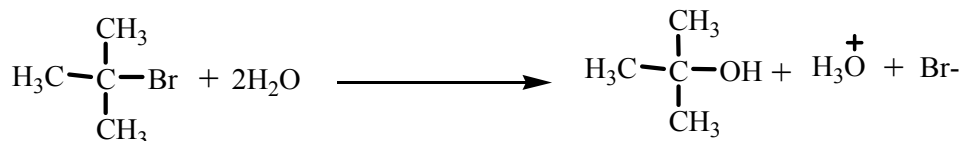

(II) S<sub>N</sub>2 reaction:

The S<sub>N</sub>2 reaction is a bimolecular nucleophilic substitution reaction because the rate-determining step involves two reacting species, i.e. the substrate and the nucleophile. It is always a single-step reaction in which a bond is broken and a new one is created simultaneously.

The S<sub>N</sub>2 reaction mechanism follows a single step in which a nucleophile attacks the substrate from the backside, which initiates the reaction. At an angle of 180° to the carbon-leaving group bond, the nucleophile approaches the substrate through a transition state, the carbon-nucleophile bond is formed and the carbon-leaving group bond breaks at the same time. Now, on the other side of the carbon-nucleophile bond, the leaving group is forced out of the transition state, generating the corresponding product.

Example: Nucleophilic substitution of chloroethane with hydroxide as nucleophile.

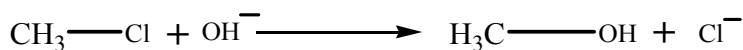

Below is a diagram of the S<sub>N</sub>2 reaction mechanism for the above reaction.

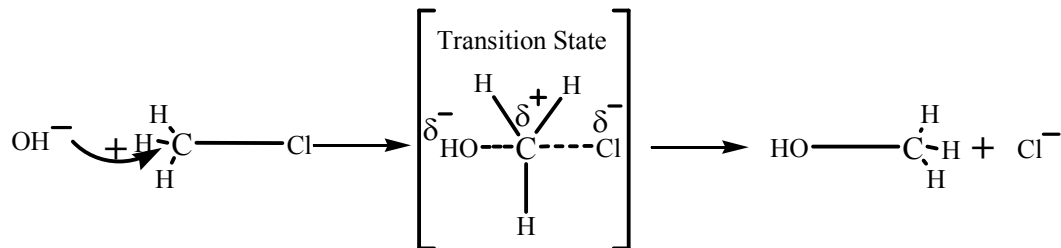

(III) S<sub>N</sub>i reaction:

In S<sub>N</sub>i, S stands for substitution, N stands nucleophilic, i stands for intramolecular.

In the S<sub>N</sub>i mechanism ( internal nucleophilic substitution), a part of the leaving group must be able to attack the substrate detaching itself from the rest of the leaving group in the process. The S<sub>N</sub>i reaction proceeds with the retention of configuration.

**Example:** Reaction of alcohol with SOCl<sub>2</sub> Thionyl chloride (SOCl<sub>2</sub>) converts primary and secondary alcohols to alkyl chlorides with the retention of configuration.

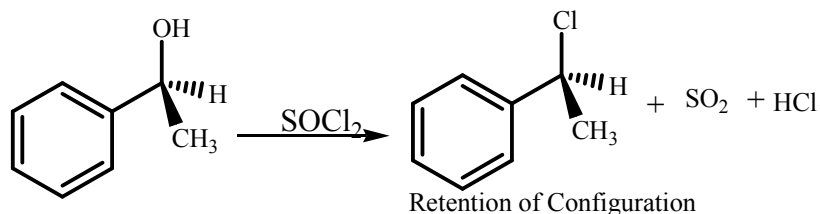

### Electrophilic substitution reaction

If a substitution reaction is brought about by an electrophile, then it is known as an electrophilic substitution reaction.

The general reaction represents the electrophilic substitution reaction.

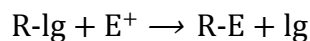

Where E<sup>+</sup> is Electrophile and lg is leaving group.

Benzene being electron-rich, is susceptible to electrophilic attack, therefore it generally gives electrophilic aromatic substitution reactions.

Electrophilic substitution of benzene involves the reaction of an electrophile with an aromatic compound. Therefore, it is more precisely called an electrophilic aromatic substitution reaction, denoted by the term S<sub>N</sub>Ar.

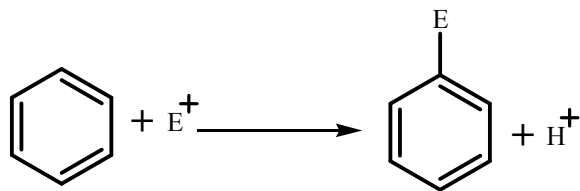

$S_NAr$  of benzene takes place in three steps:

1. Generation of an electrophile
2. Formation of a carbocation intermediate
3. Removal of a proton from the carbocation intermediate

Various types of electrophilic substitution reactions are:

Halogenation, Nitration, Sulphonation, Friedel-craft alkylation, and Friedel-craft acylation.

Example: In halogenation of benzene, reaction of bromine or chlorine occurs in the presence of a lewis acid to give the corresponding halogenated substitution products in good yield.

## Elimination Reactions

In some organic reactions, atoms from two adjacent carbon atoms are eliminated to form a product containing stronger bond. Such organic reactions are known as elimination reactions. and  $E_1$  is a unimolecular elimination reaction.

As a result of the formation of numerous bonds at the same time, tiny molecules like  $H_2O$ ,  $HCl$ , etc. are released as products.

Example: Converting ethyl alcohol to ethene is one of the common example of an elimination reaction.

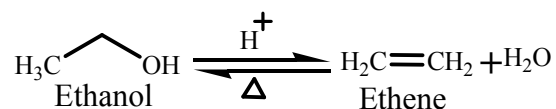

In the above reaction  $H_2O$  molecule is eliminated.

$E_1$ ,  $E_2$  and  $E1cB$  are the commonly studied elimination reactions.

### **$E_1$ elimination reaction**

In  $E_1$  elimination, the leaving group leaves the substrate first to form a carbocation intermediate. Then, the proton abstraction takes place to form an alkene. Example: Dehydrohalogenation of an alkyl halide in the presence of water.

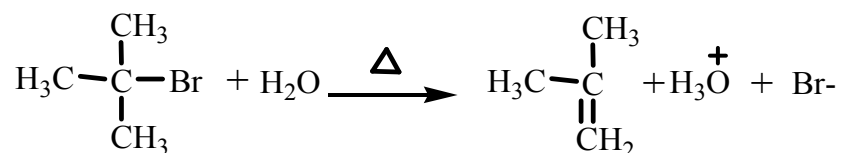

### **$E_2$ elimination reaction**

In  $E_2$  elimination, two groups/atoms depart simultaneously from adjacent carbons along with the proton being abstracted by a base. And  $E_2$  is a bimolecular elimination reaction.

**Example:** Dehydrohalogenation of an alkyl halide in presence of base,  $\text{RONa}$ .

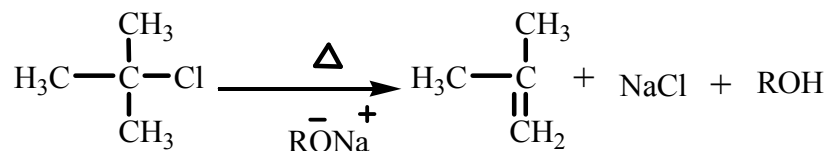

### **$E1cB$ elimination reaction**

In  $E1cB$ ,  $E$  stands for elimination, 1 for unimolecular, and  $cB$  for conjugate base. In  $E1cB$ , the proton is abstracted to form the conjugate base. The anion that results is stable enough

to exist because it can be delocalised on to the electron-withdrawing group. Although the anion is stabilized by the electron-withdrawing group, it still prefers to lose a leaving group and become an alkene.

**Example:**

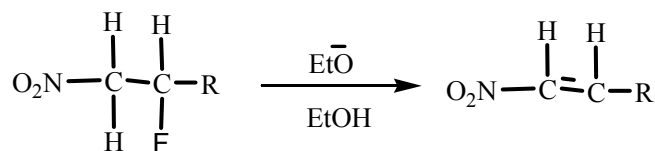

### Conditions for E1cB Elimination

There are two conditions for any molecule to give E1cB elimination reaction:

A good electron withdrawing group must be present at the  $\beta$ -position to the leaving group and the poor leaving group at  $\alpha$ -position

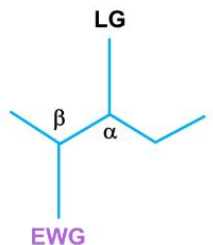
|  |  |
|--|--|
|  | <p><i>good electron withdrawing group</i></p> <p>Carbonyl (- C = O), nitro (- NO<sub>2</sub>), cyano (-C = N), sulphonyl (- SO<sub>2</sub> -), Phenyl (- Ph), ester (- COOR), and other carbonyl stabilizing groups.</p> <p><i>poor leaving group</i></p> <p>-F, -OH, etc.</p> |
|--|--|

### Addition Reactions

An addition reaction as the reaction involving the addition of two reactants resulting in a larger product, and the product of the addition reaction is known as 'Adduct'. The chemical compounds possessing multiple bonds undergo an addition reaction, as the basic principle behind the reaction is the compound's ability to break double or triple bonds. An addition reaction is just the reverse of an elimination or reduction reaction. For example, when HCl is added with ethylene in the process shown below, it produces ethylene chloride.



Depending on the nature of the reactant (alkene, alkyne, carbonyl) and the substrate (electrophile and nucleophile) addition reactions are majorly of two types, Electrophilic and nucleophilic addition reaction.

## Electrophilic addition reaction

The process of electrophilic addition with an alkene takes place in such a manner that the added electrophile generates the most stable carbocation intermediate. During this reaction, a carbocation is formed on the most stable carbon in the compound when the  $\pi$  electron attacks an electrophile. This is followed by an attack on the carbocation by the nucleophile leading to the formation of the required product.

The general mechanism of electrophilic addition in alkenes is given below:

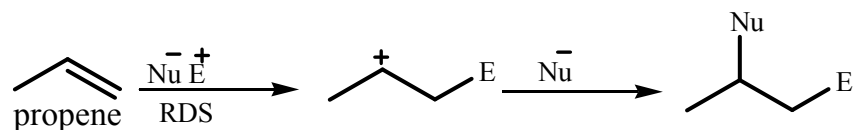

One such example is of addition of HCl to alkene.

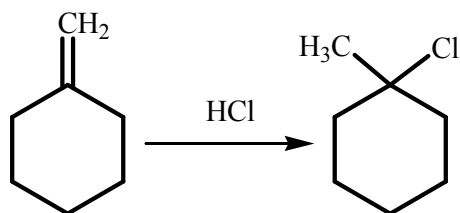

## Nucleophilic addition reaction

Nucleophilic addition reaction involves a chemical compound possessing an electron-deficient double or triple bond or an electron deficient  $\pi$  bond that reacts with a nucleophile (an electron-rich reactant). Thus, generally the double bond disperses and results in the formation of two new  $\sigma$  bonds. Such reactions are shown by carbonyl compounds.

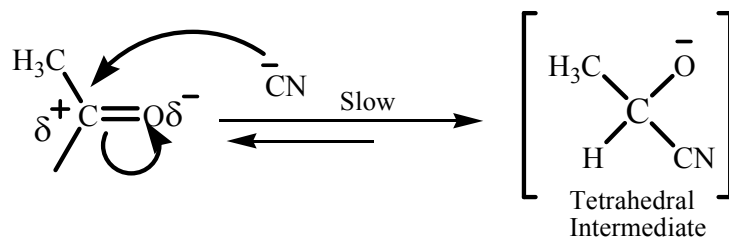

## Rearrangement reaction

Organic reactions in which atoms, groups (alkyl or aryl), double bonds, or functional groups migrate within the molecule are known as rearrangement reactions.

It is a broad category of chemical processes in which the carbon atoms in a molecule are rearranged to produce a structural isomer of a parent molecule. There are also intermolecular reorganizations of atoms.

Some rearrangement reactions are Beckmann rearrangement, Baeyer-Villiger oxidation, rearrangement of carbocation.

In rearrangement of carbocation, there are two types rearrangement:

**Cyclic rearrangement:** They are of two types: Ring expansion and ring contraction.

**Example:** Ring contraction will only happen if a more stable carbocation is formed after contraction. Thus ring contraction occurs in order to form the most stable carbocation. A cyclopropyl methyl carbocation is formed, which is highly stable.

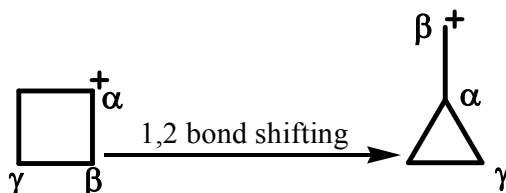

**2) Acyclic rearrangement:** They are of three types: 1,2-hydride shift, 1,2-alkyl shift, and 1,2-aryl shift.

**Example-** In the below example 1,2 methyl shift occurs to form more secondary carbocation from unstable primary carbocation.

